

CÍL *Měsíc*



Ing. Tomáš PŘIBYL
tomas.pribyl@seznam.cz
www.kosmonaut.cz













THE OLDEST DAILY NEWSPAPER IN THE UNITED STATES—FOUNDED 1773

The Philadelphia Inquirer

FINAL CITY EDITION

PUBLIC LEDGER

AN INDEPENDENT NEWSPAPER FOR ALL THE PEOPLE

PHILADELPHIA, THURSDAY, NOVEMBER 22, 1963. PRICE: 50 CENTS. (CITY) PHILADELPHIA, PA. (7) TELEPHONE: 233-1211. CIRCULATION: 1,000,000.

KENNEDY SHOT TO DEATH

Johnson Is Sworn In as President

Asks Support Of Nation, Divine Help

By WALTER WINSTON

JOHNSON, 55, took the oath of office in the presence of the Supreme Court, Chief Justice Warren, and other dignitaries in the White House. He was accompanied by his wife, Lady Bird, and their two children. Johnson's inaugural address was broadcast on television and radio. He called for national unity and support for his administration.



A motorcade carrying President Kennedy's coffin through the streets of Dallas, Texas, on Wednesday, Nov. 22, 1963. The motorcade was a somber occasion for the people of Dallas.

Sniper Rifle Found In Textbook Loft; Gov. Connally Hit

By FRANK CORBIE

DALLAS, Tex., Nov. 22 (AP)—A hidden sniper rifle was found in a textbook store in Dallas today, and Gov. Connally was hit by a bullet during a motorcade in Dallas.

The rifle was found in a loft above the store. It was a .300 Winchester Magnum. The bullet that hit Connally was fired from this rifle. The rifle was found in a textbook store.

The rifle was found in a loft above the store. It was a .300 Winchester Magnum. The bullet that hit Connally was fired from this rifle. The rifle was found in a textbook store.

WAS IN BUILDING

The rifle was found in a building. It was a .300 Winchester Magnum. The bullet that hit Connally was fired from this rifle. The rifle was found in a building.

The rifle was found in a building. It was a .300 Winchester Magnum. The bullet that hit Connally was fired from this rifle. The rifle was found in a building.

THREE MORE WOUND

Three more people were wounded during the motorcade. They were all hit by bullets. The wounds were not serious.

The wounds were not serious. The people who were wounded are recovering from their injuries. The police are investigating the shooting.

Leftist, 24, Is Jailed As Suspect; Also Held In Policeman Slaying

By JOHN J. WILSON

A 24-year-old leftist was arrested today on suspicion of the slaying of a policeman. He is also being held as a suspect in the assassination of President Kennedy.

The man, whose name is being withheld, was arrested in a police raid. He is being held in a jail.

The man is being held in a jail. He is being held on suspicion of the slaying of a policeman. He is also being held as a suspect in the assassination of President Kennedy.



Funeral Rites For President To Be Monday

By JOHN J. WILSON

Funeral rites for President Kennedy will be held in Dallas on Monday. The funeral will be broadcast on television.

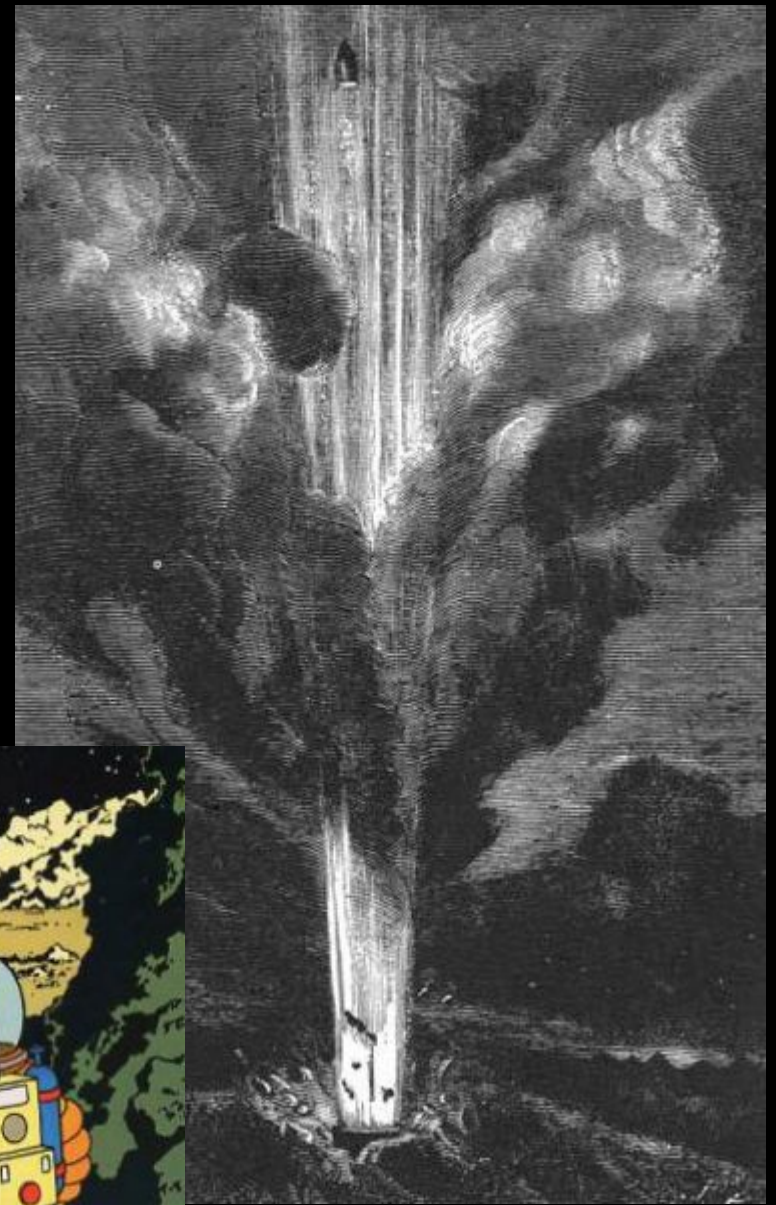
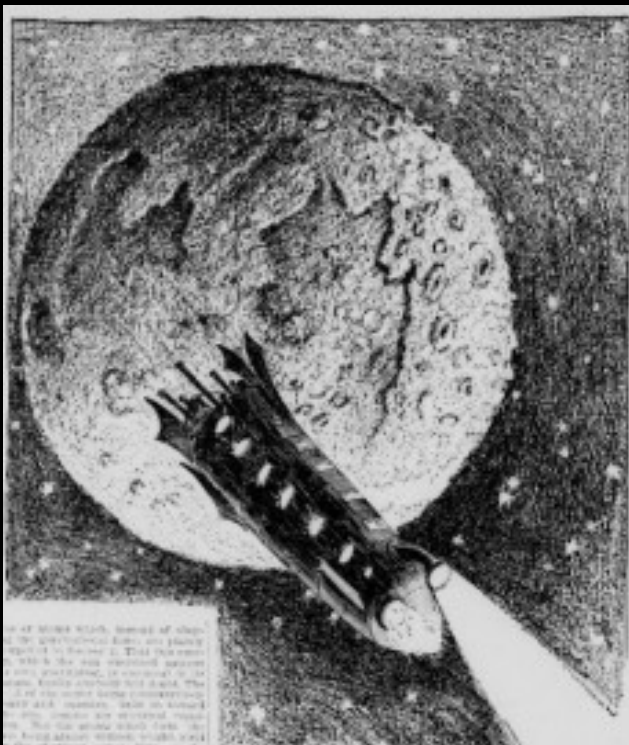

PROJECT APOLLO

LUNAR LANDING FLIGHT TECHNIQUES

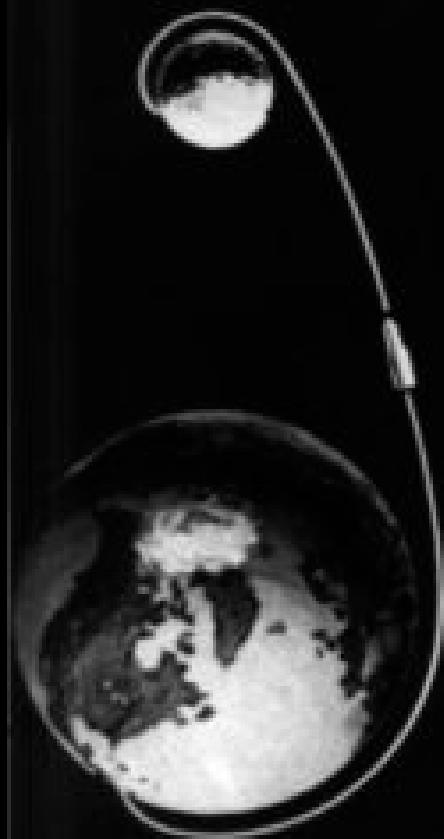

DIRECT



**EARTH ORBIT
RENDEZVOUS**

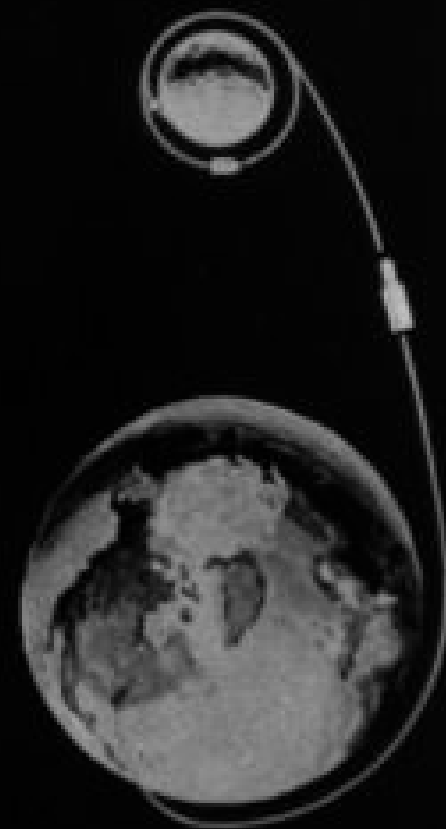

**LUNAR ORBIT
RENDEZVOUS**

John Houbolt

VEHICLE

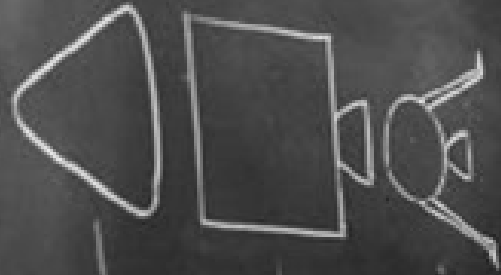

C.M. S.M. L.E.V.

ESCAPE WEIGHTS
L.O.R.



MISSION



COMPARISON OF LANDER SIZES

DIRECT LANDING

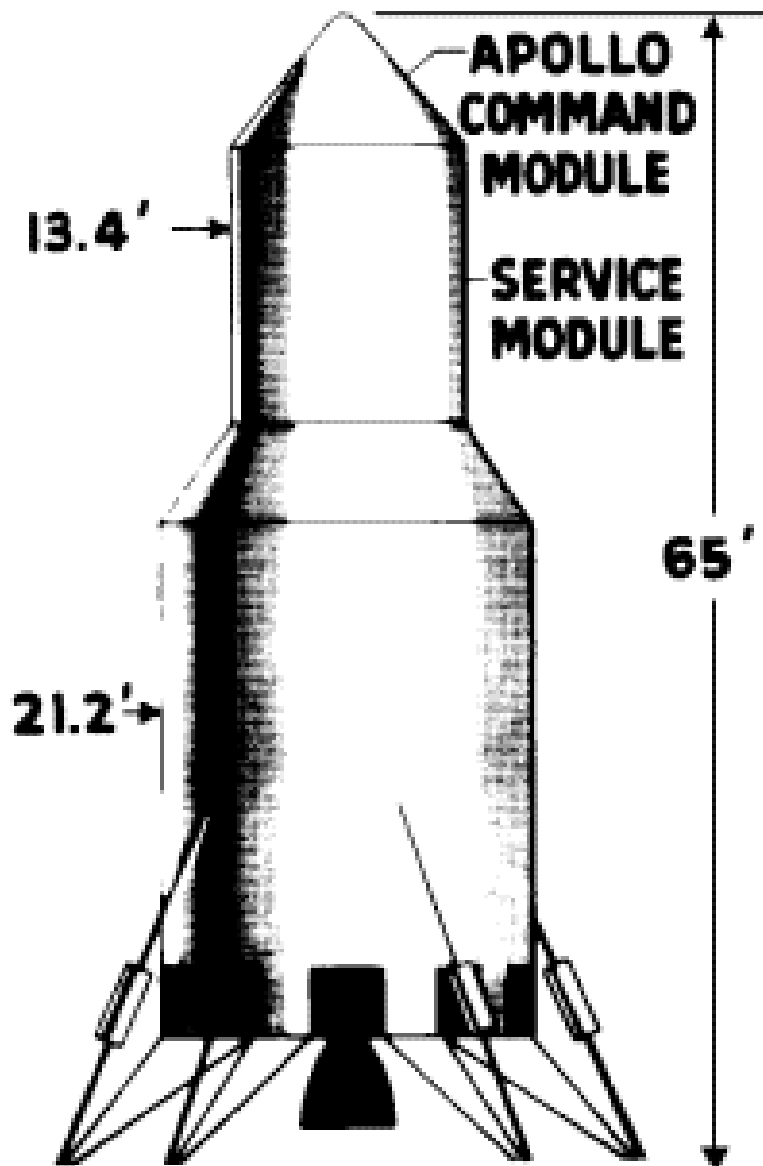

LUNAR FERRY OF LUNAR RENDEZVOUS

LUNAR EXCURSION VEHICLE

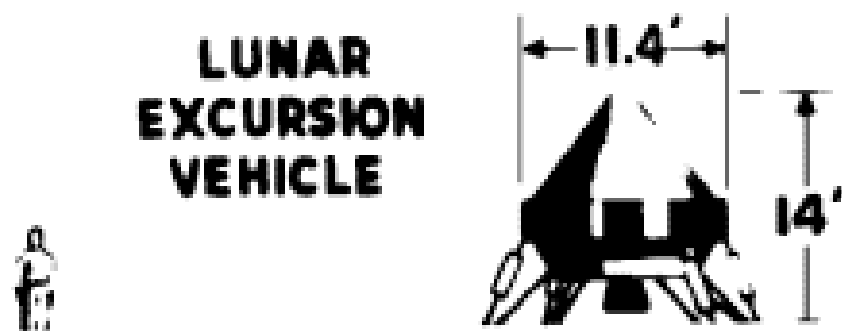



Výška 110,7 m

Hmotnost 2970 t

Kapacita 145 t





Tajemství úspěchu











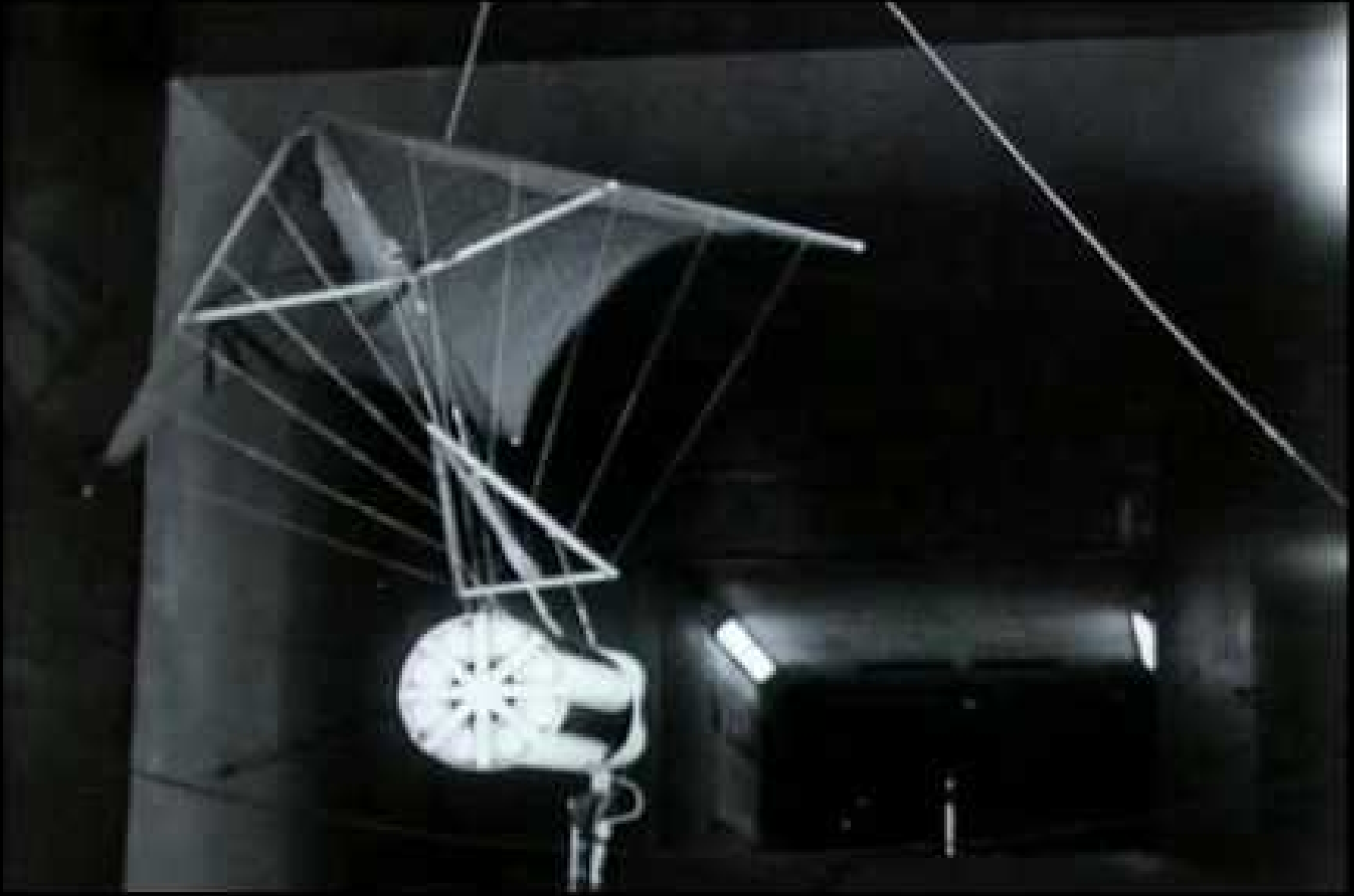

Balóny? Křídla? Posádka?

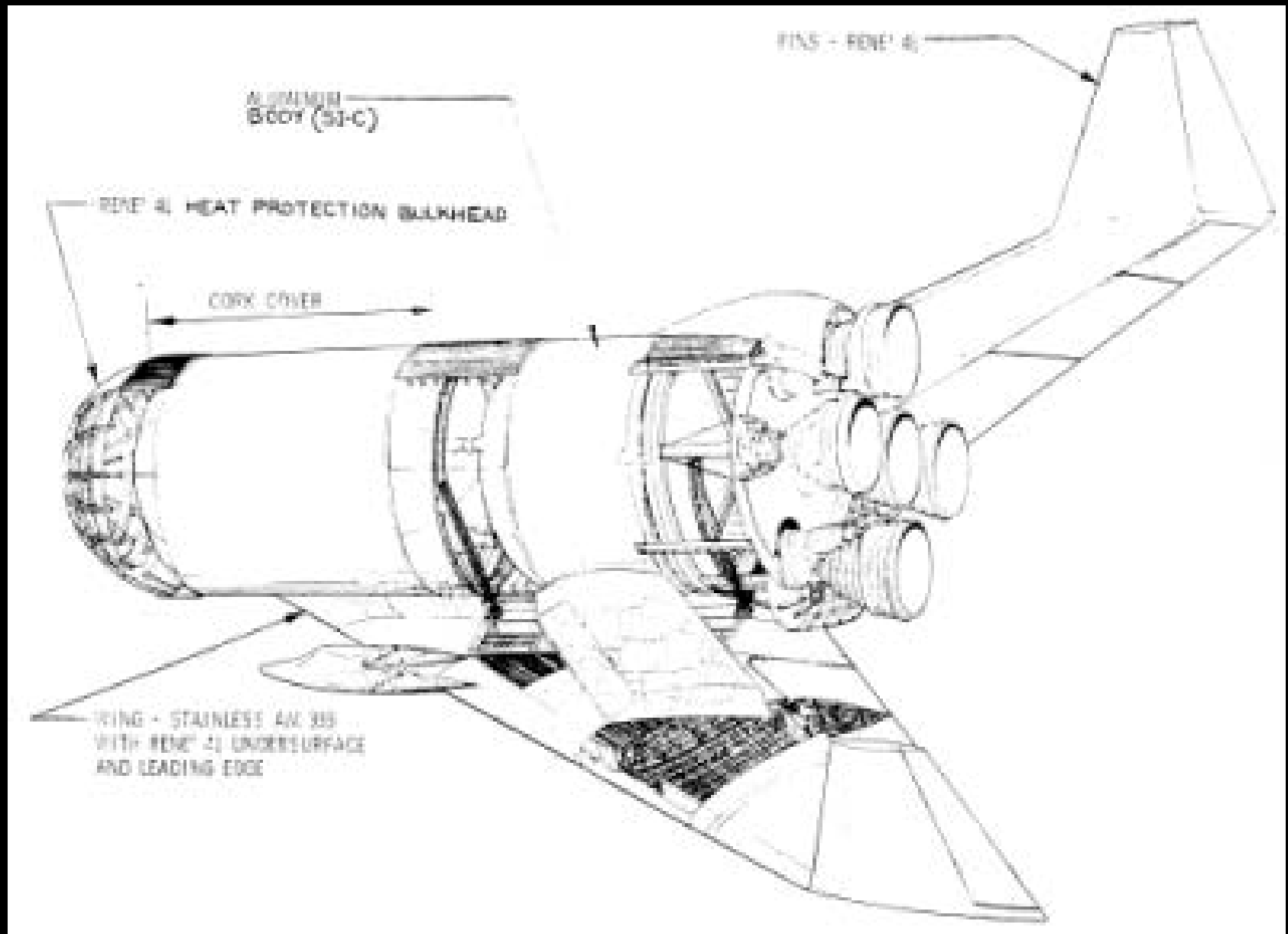

Hiller Aircraft

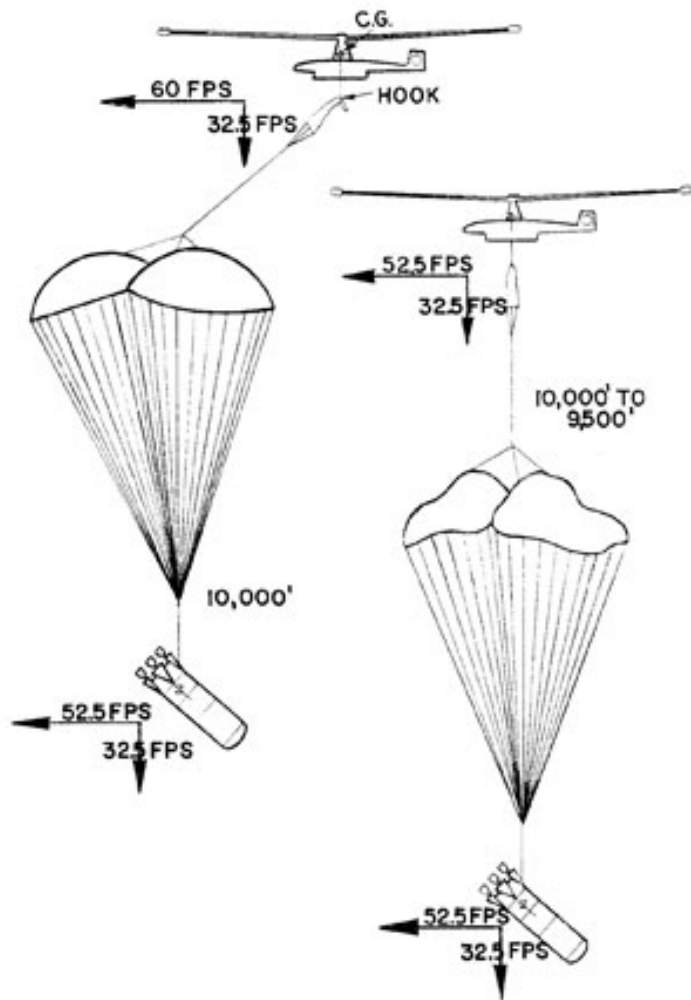

BOOSTER ENGAGEMENT

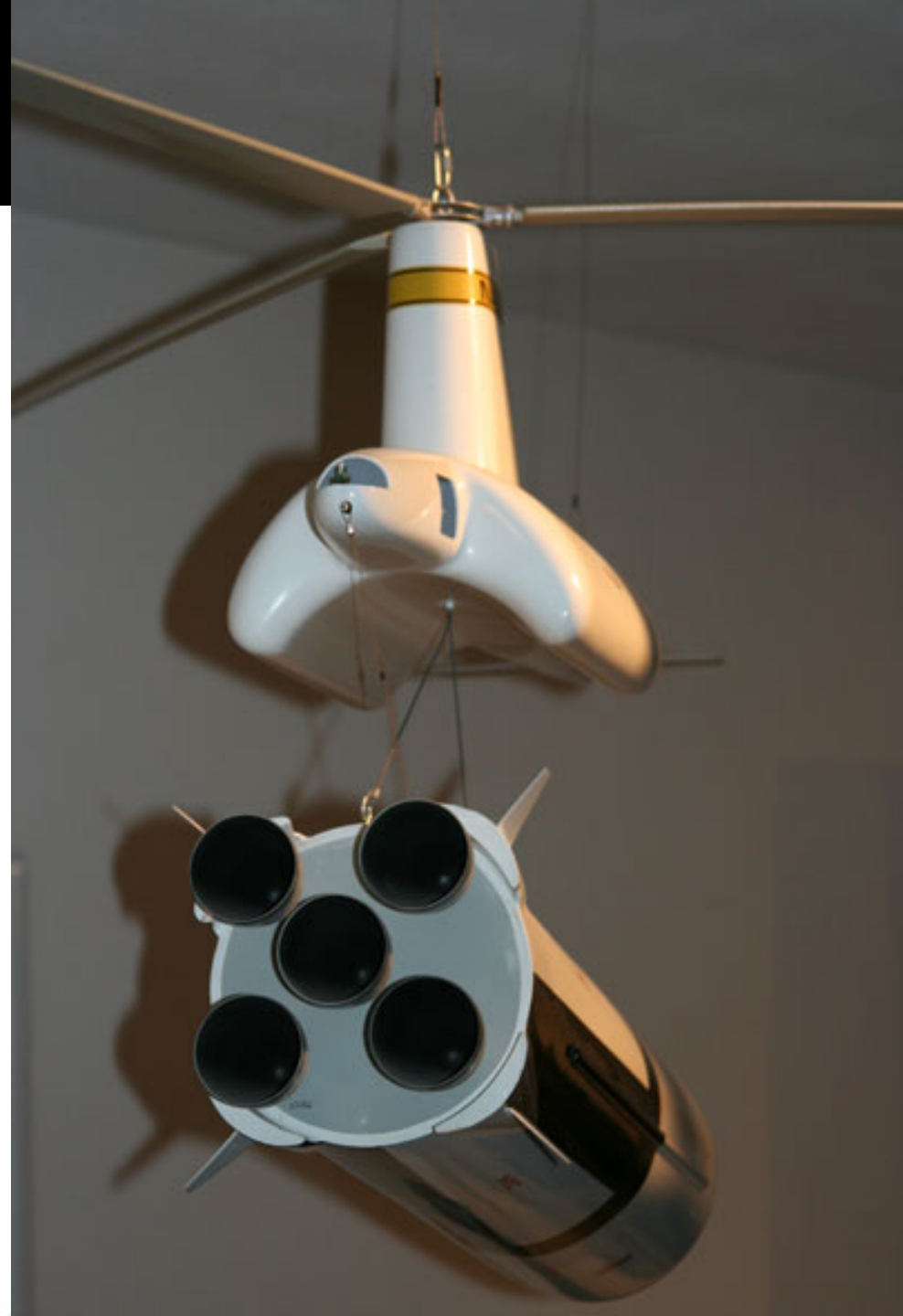

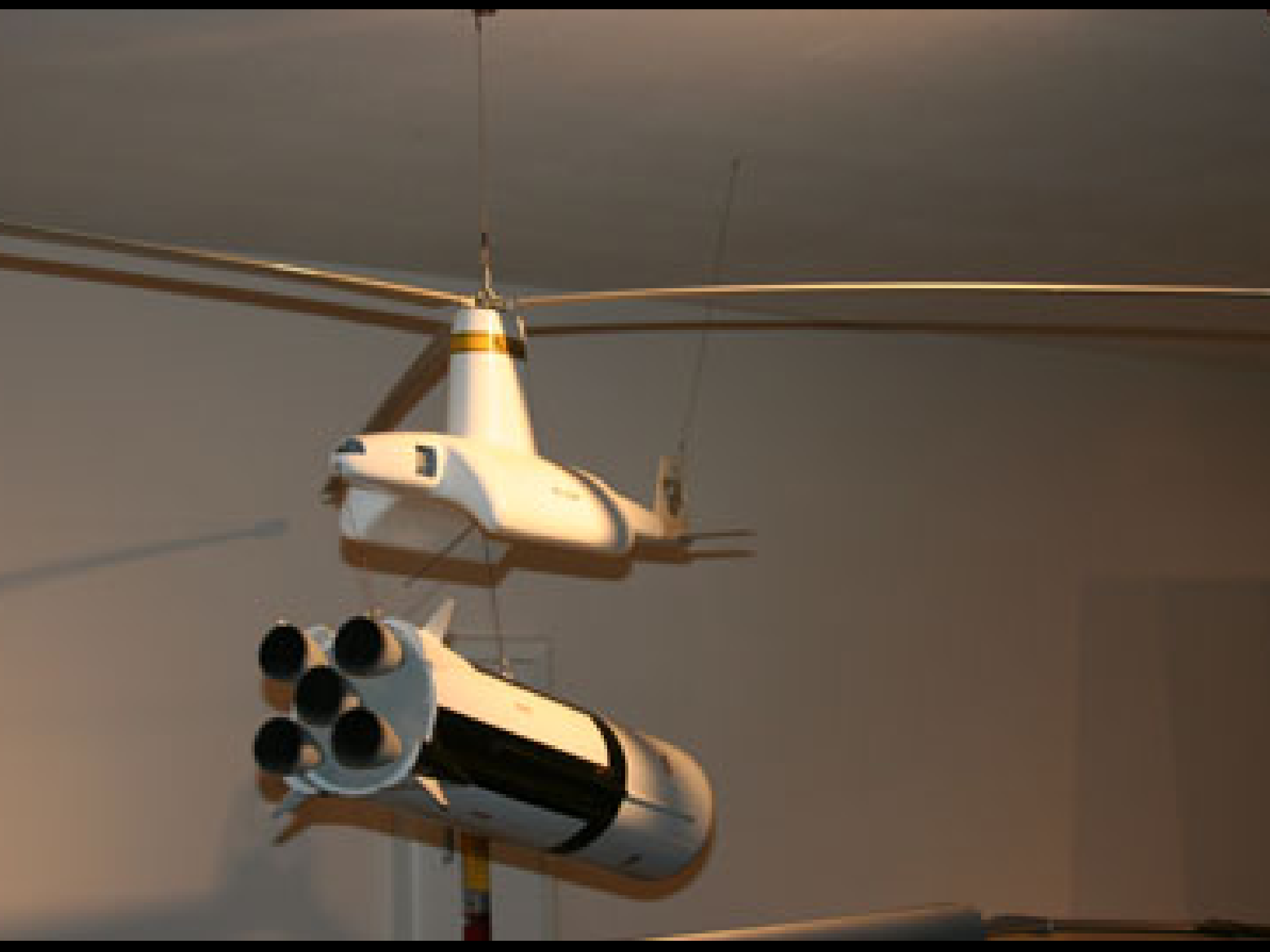

Přistání na hladinu

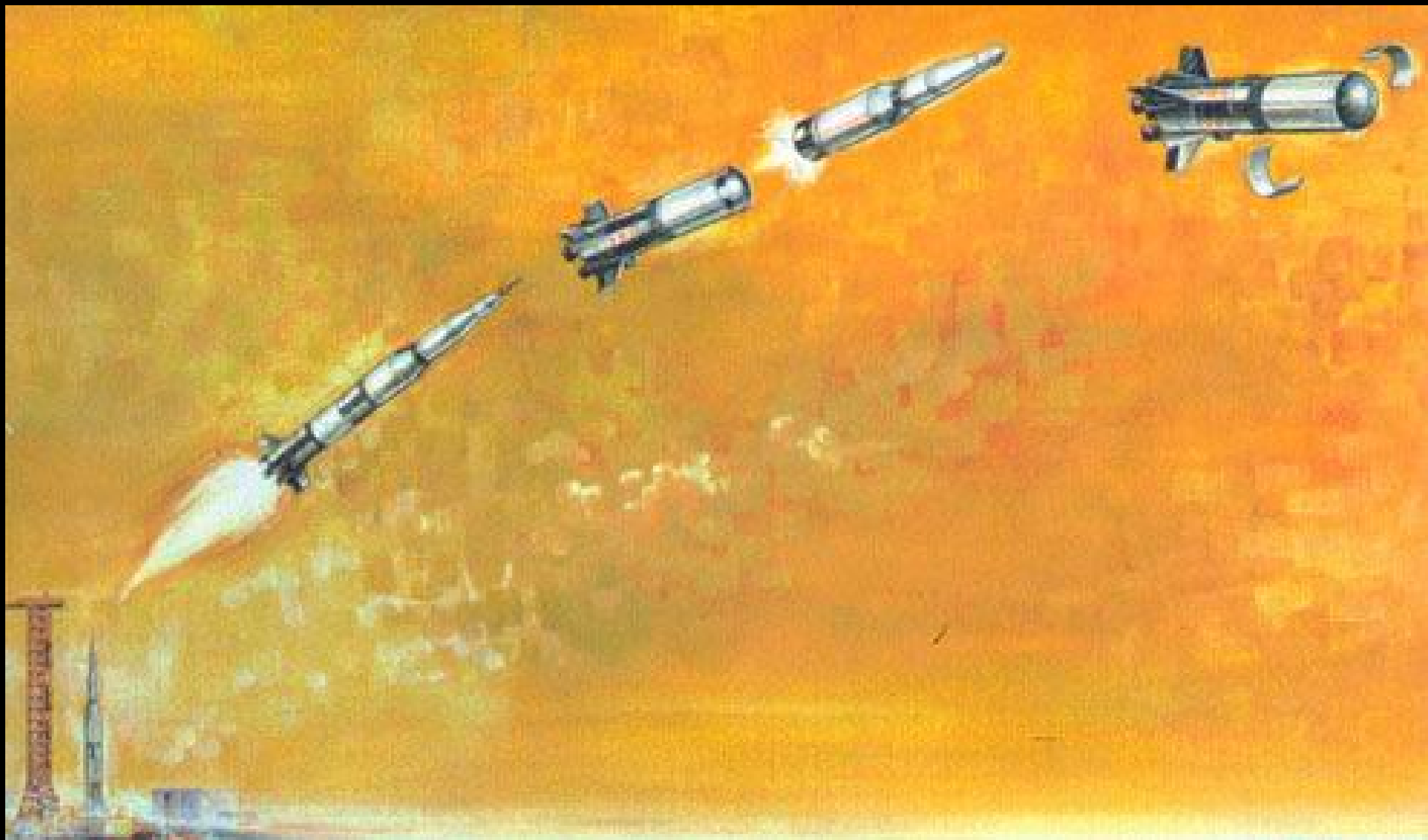



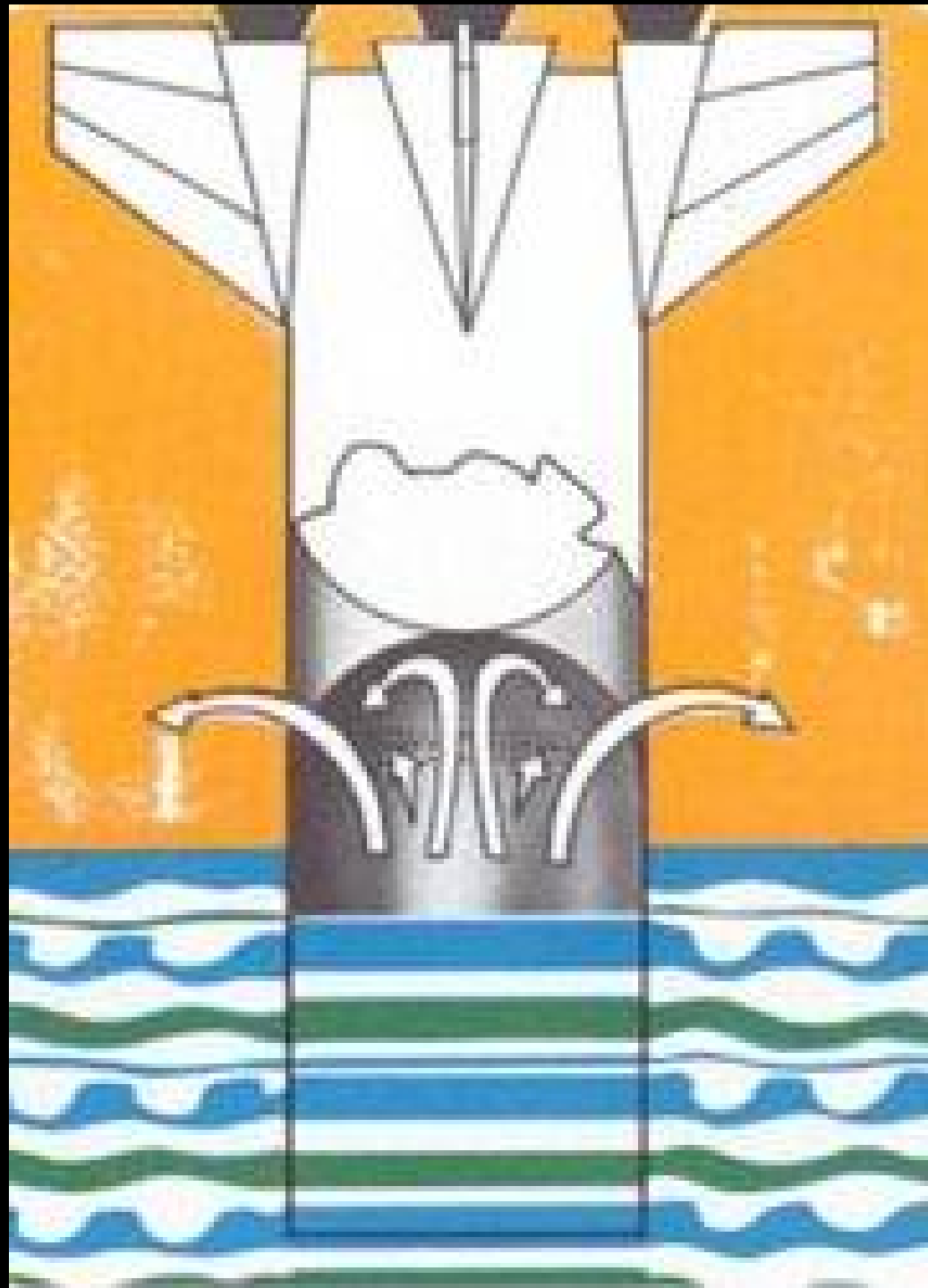





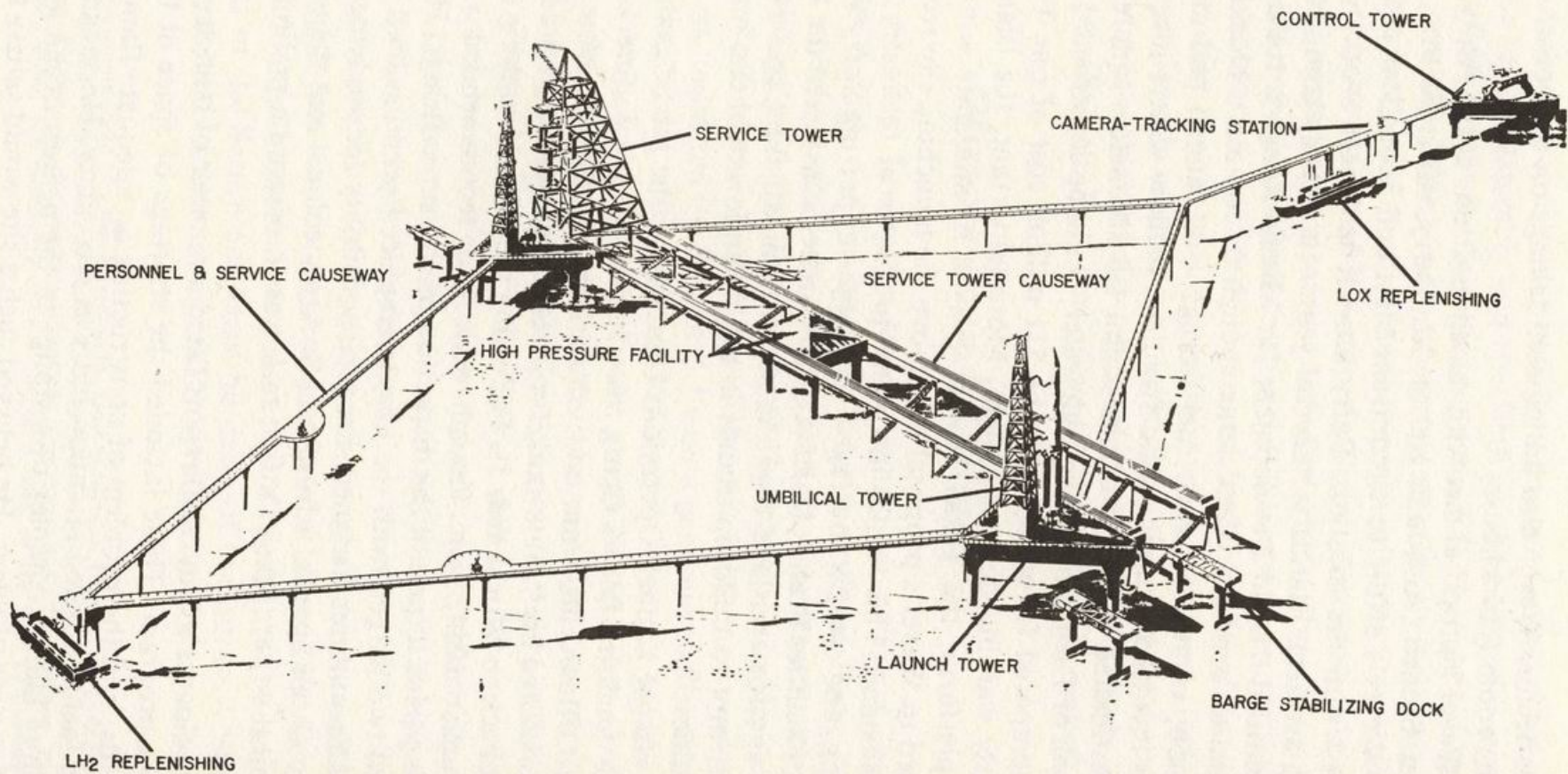

Červenec 1950

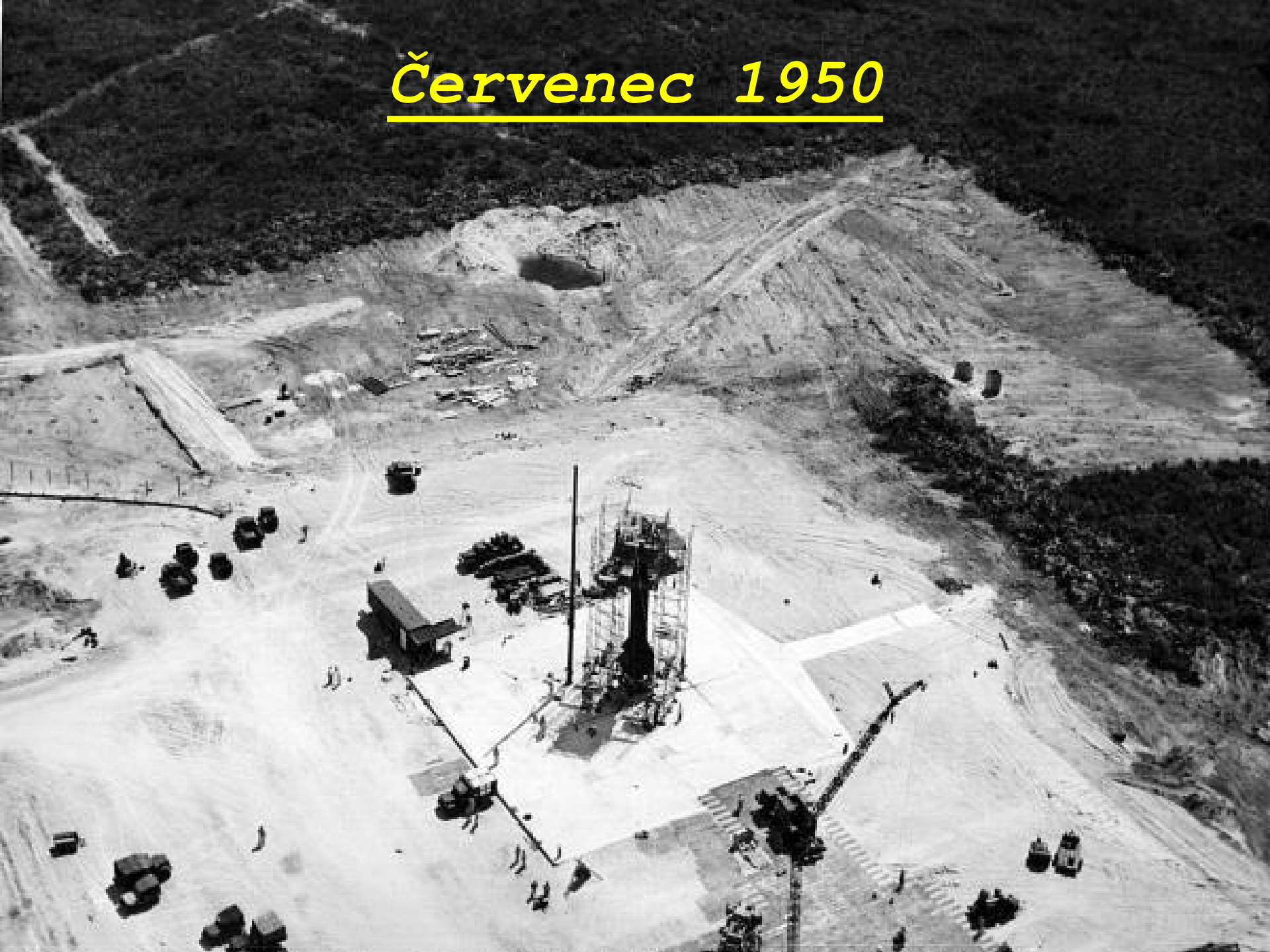



1962 – pozemky na ostrově Merritt



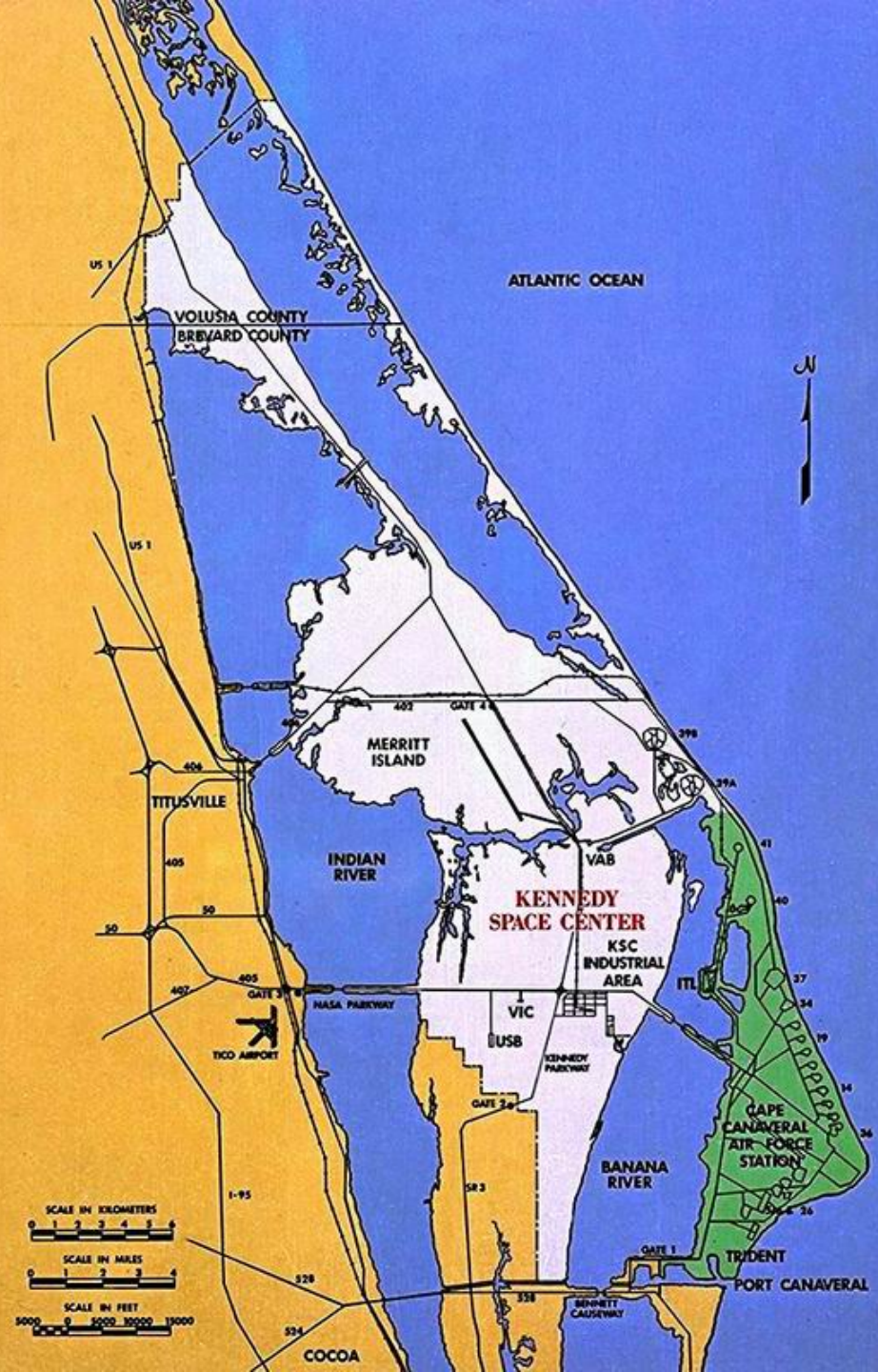

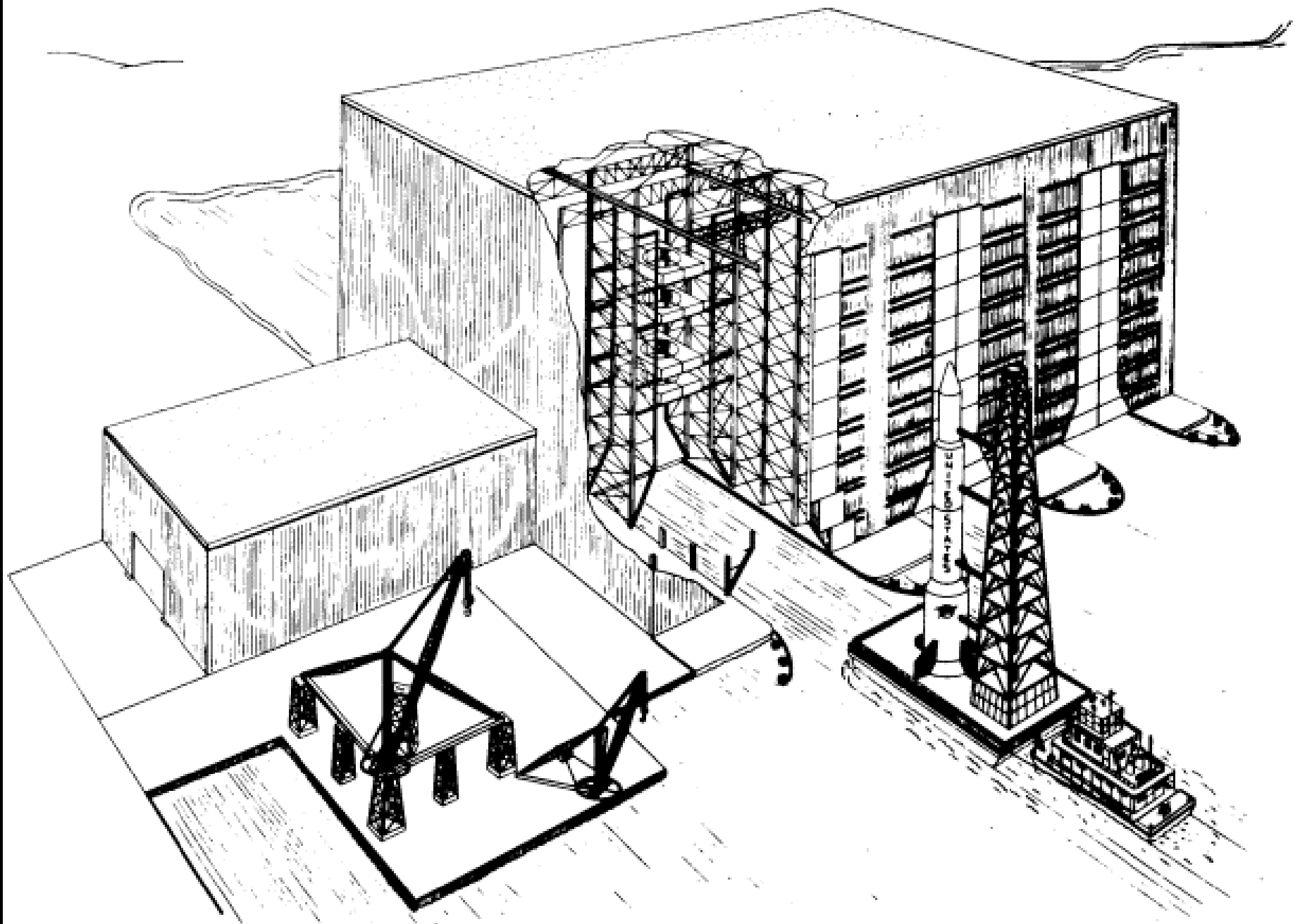

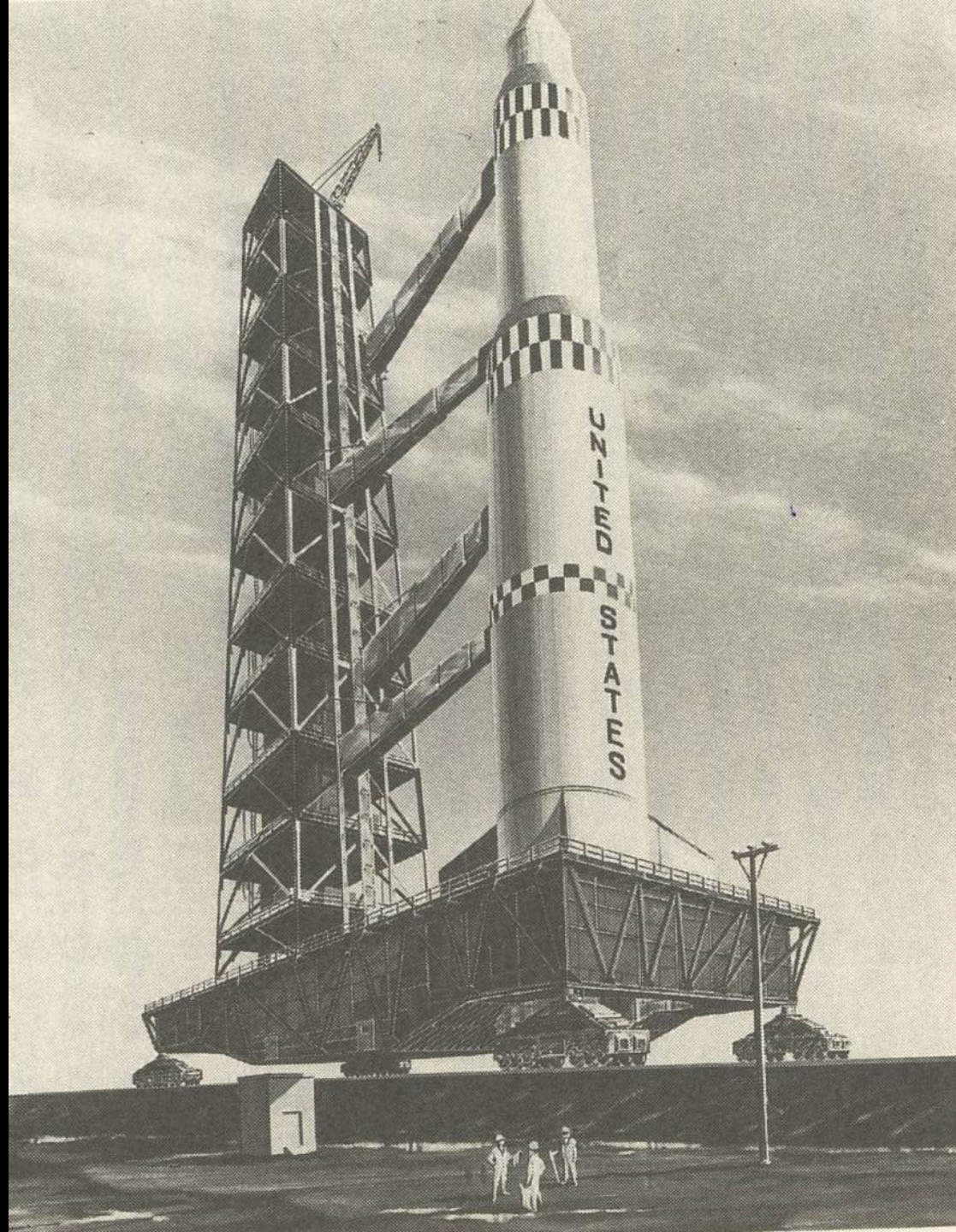

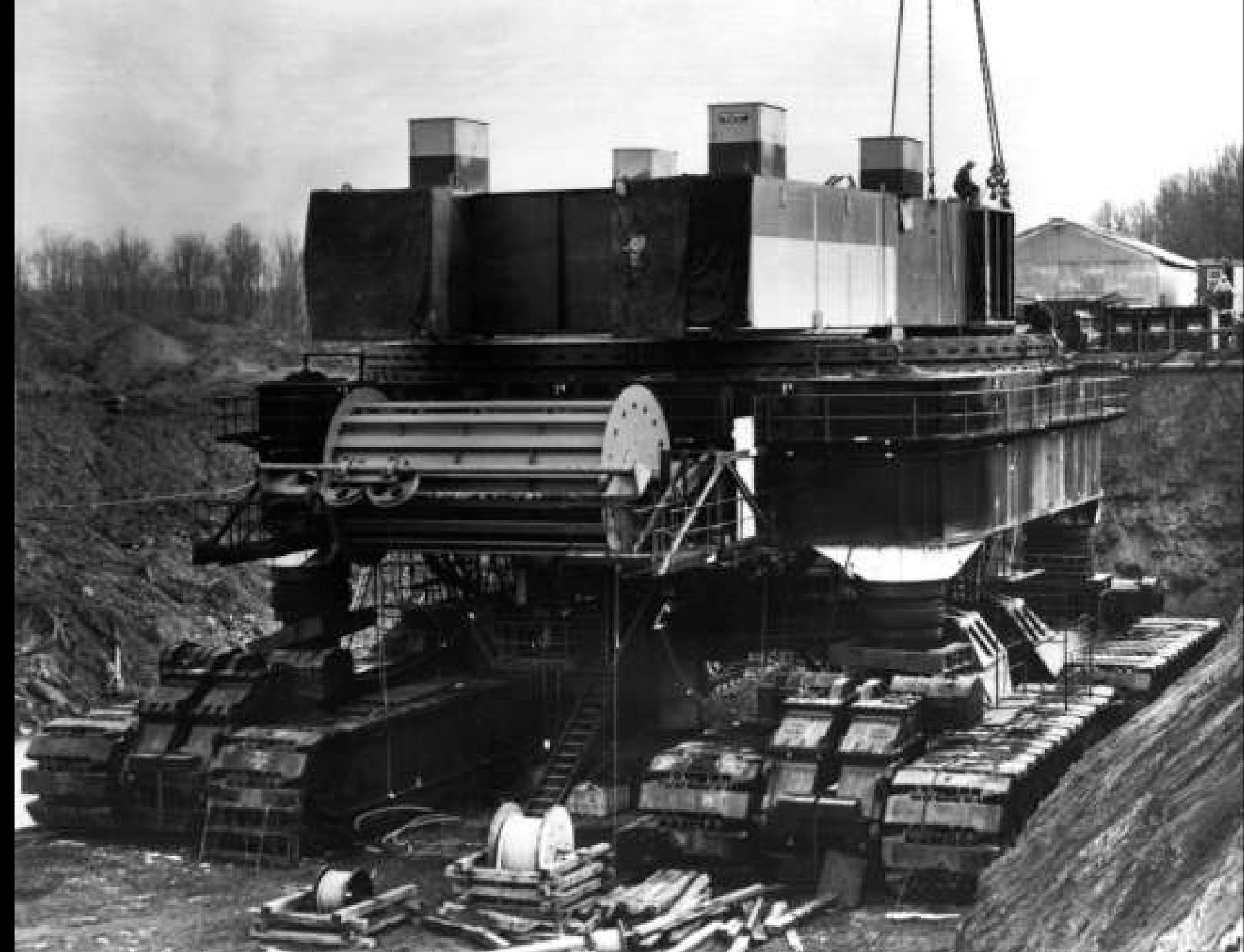





Základy 46 až 52 m (4225 ks)
Pilíř 16 m, průměr 41 cm



11. července 1963



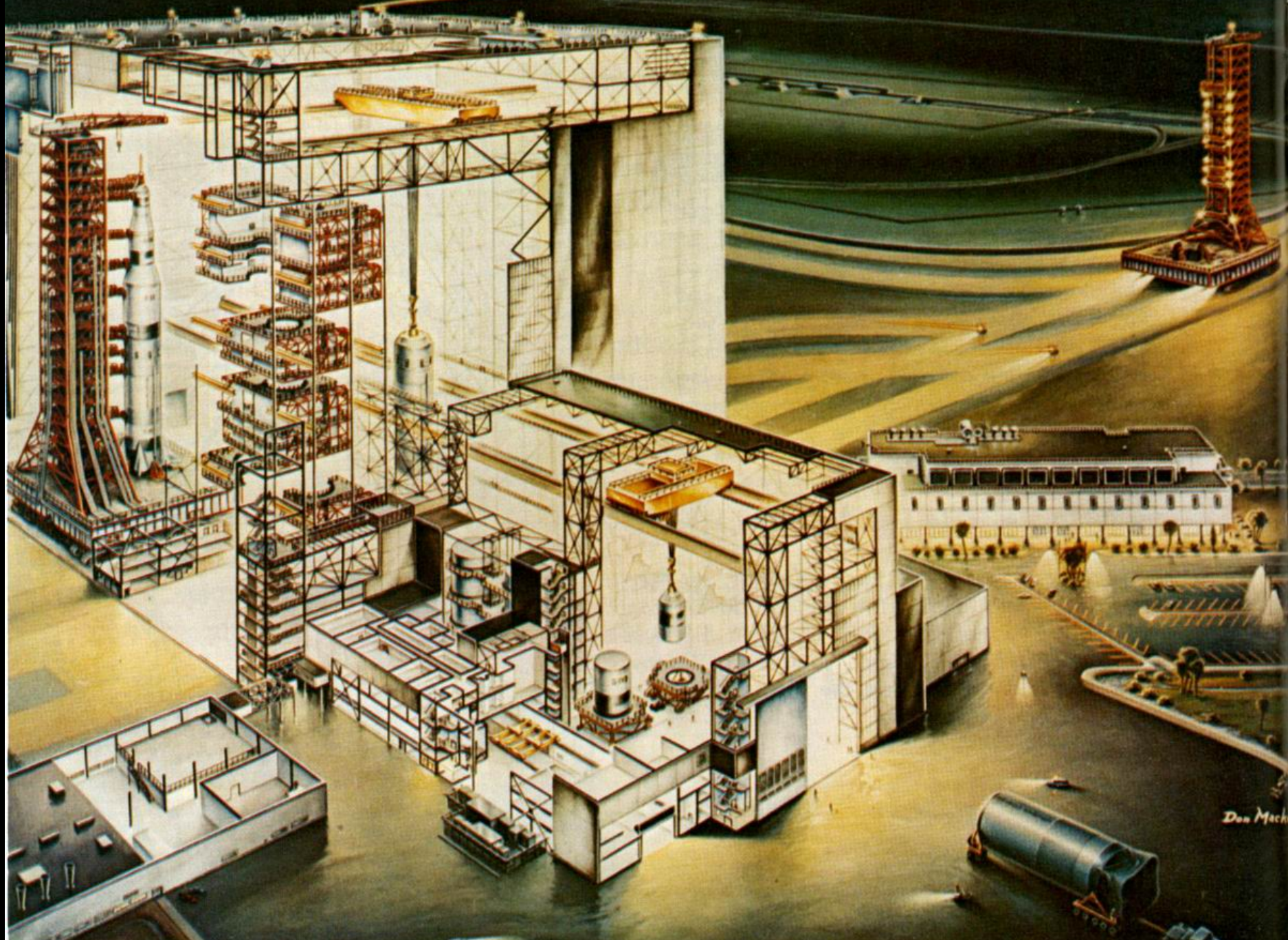

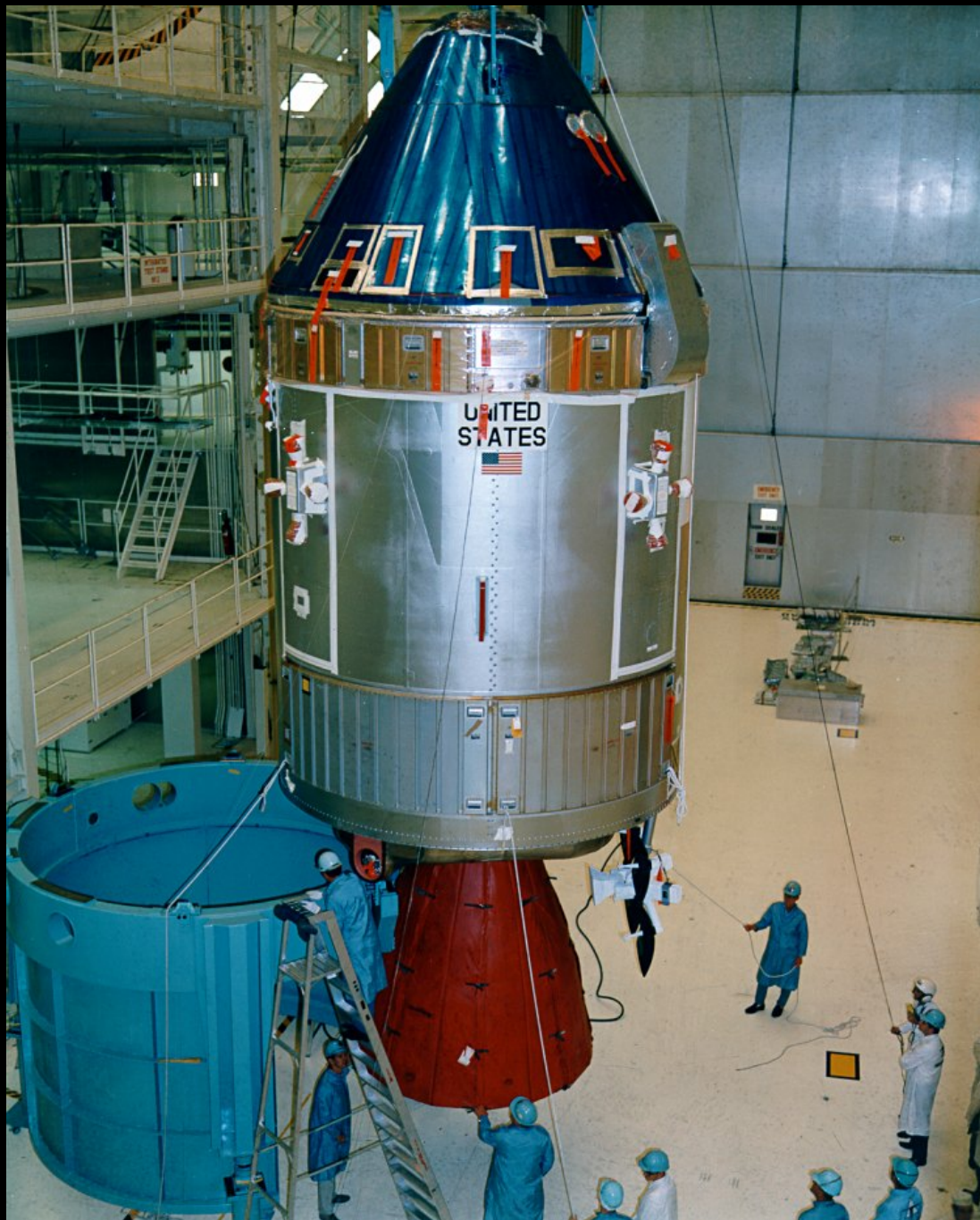

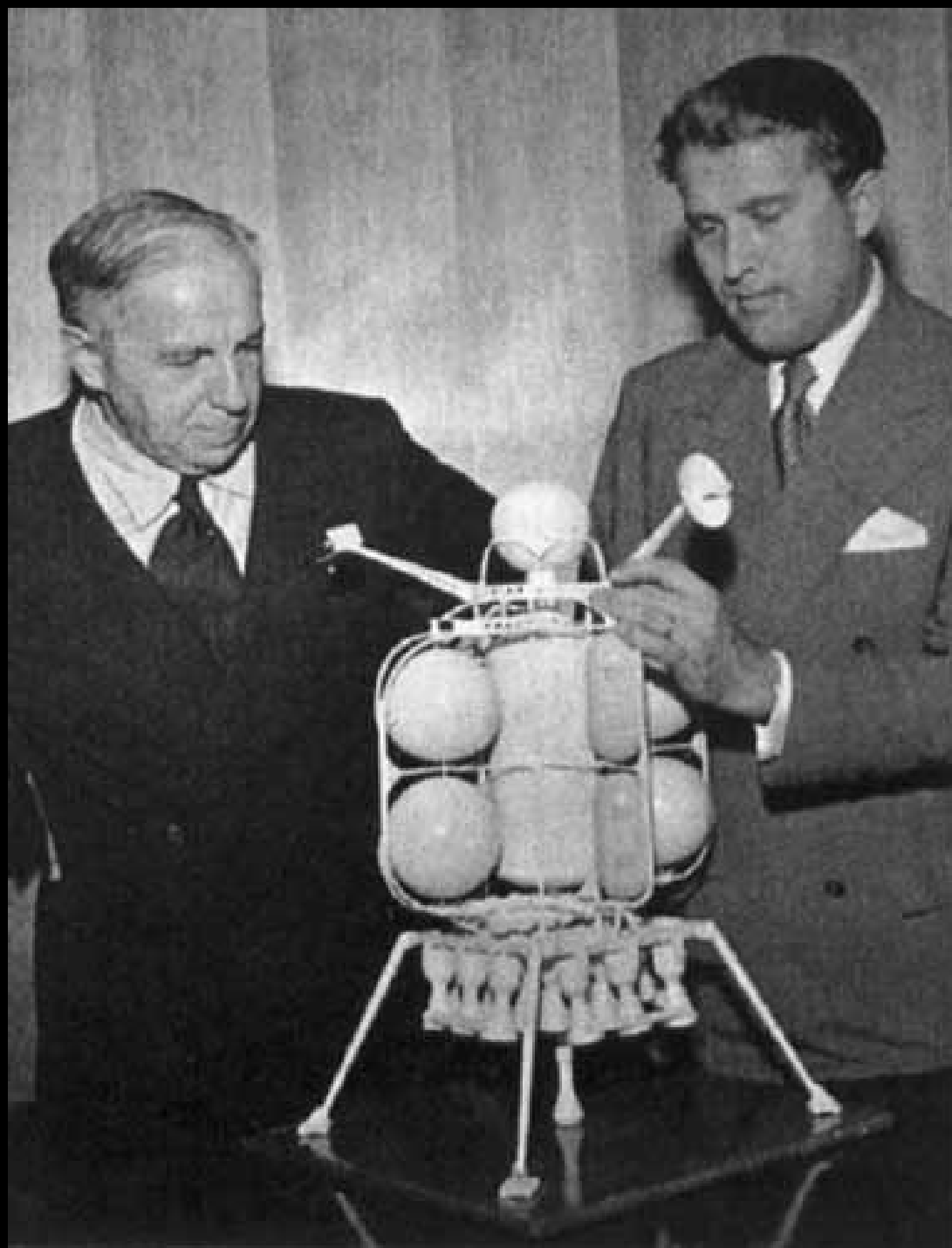

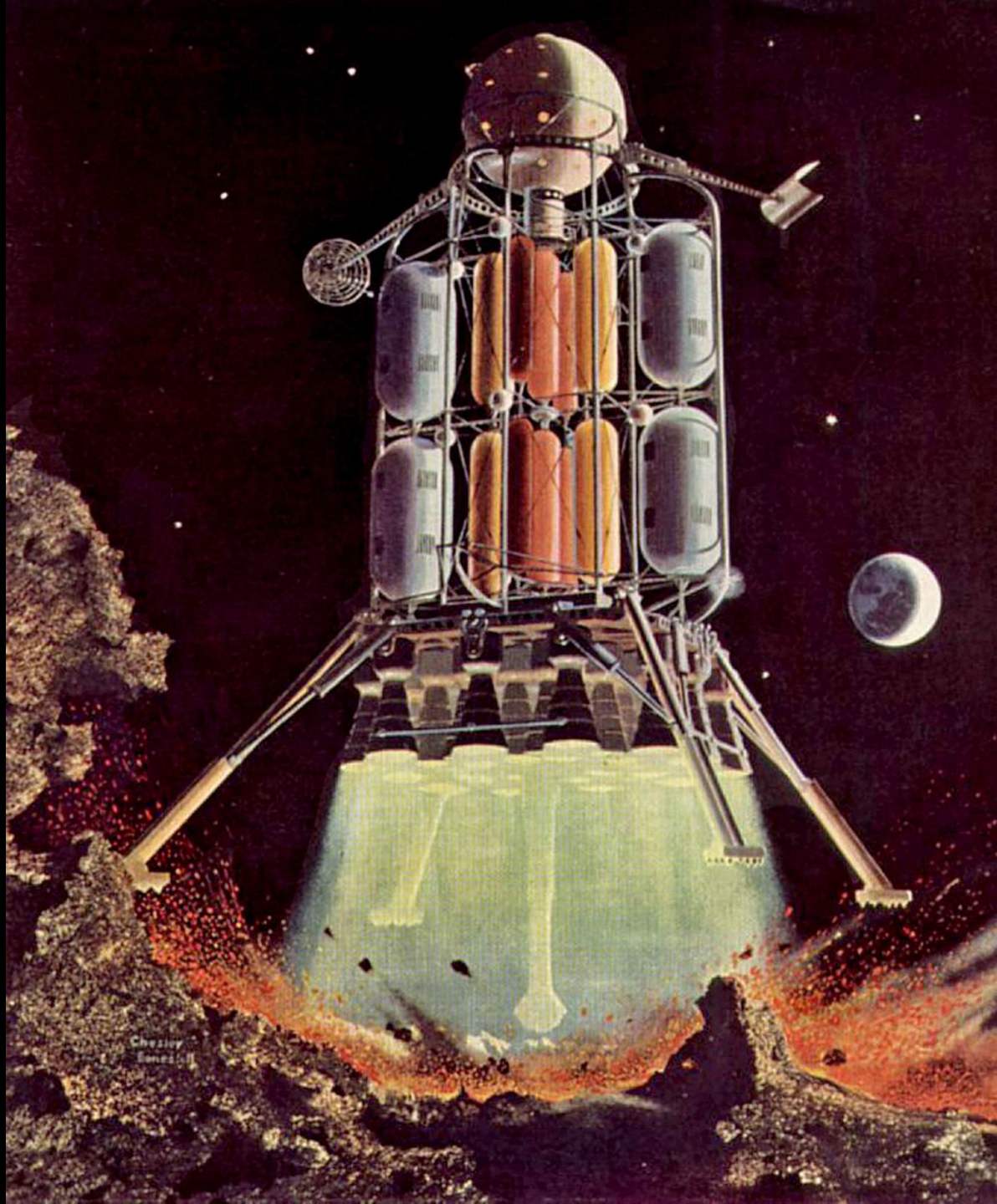

Chester
Gomez



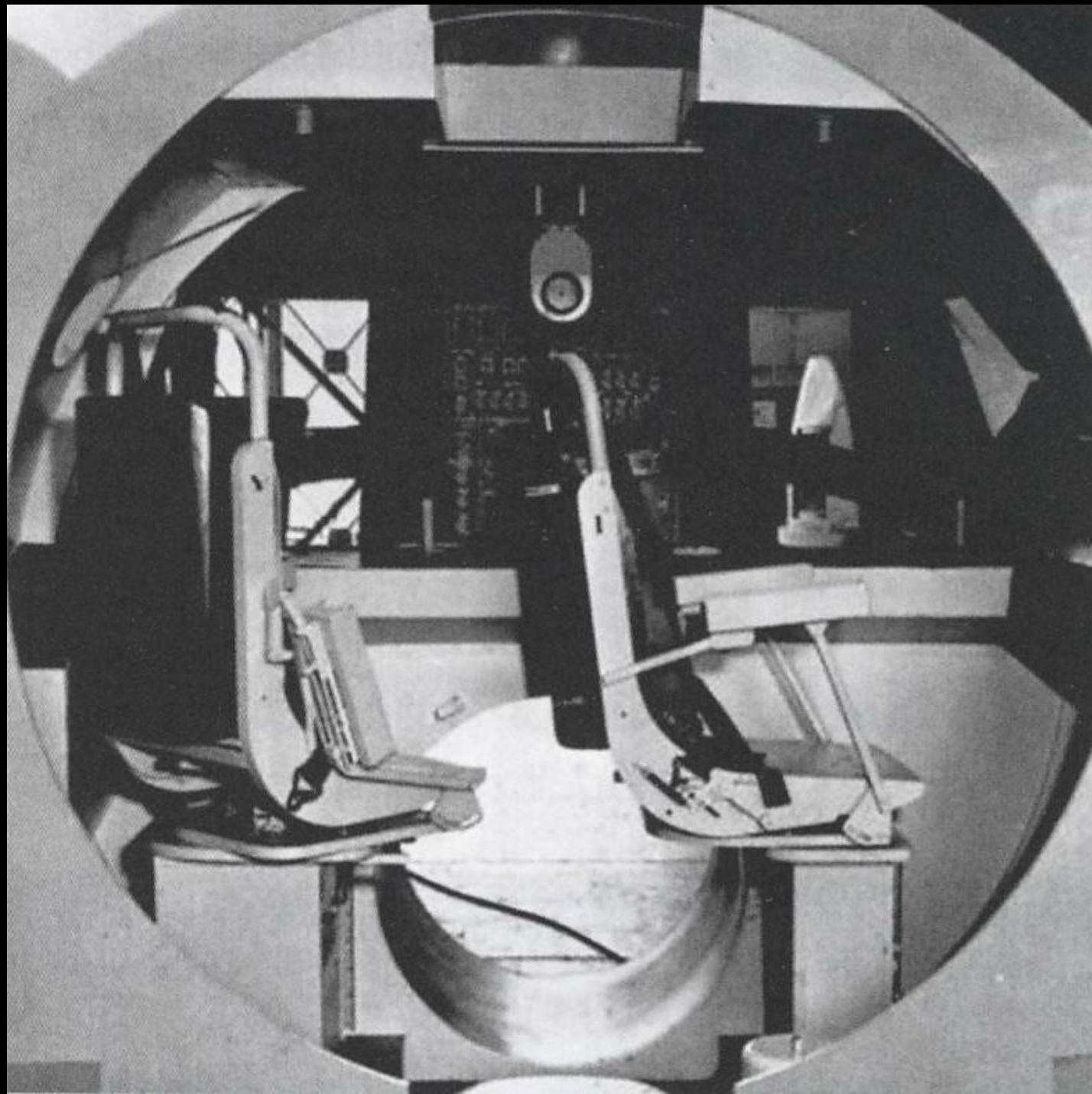



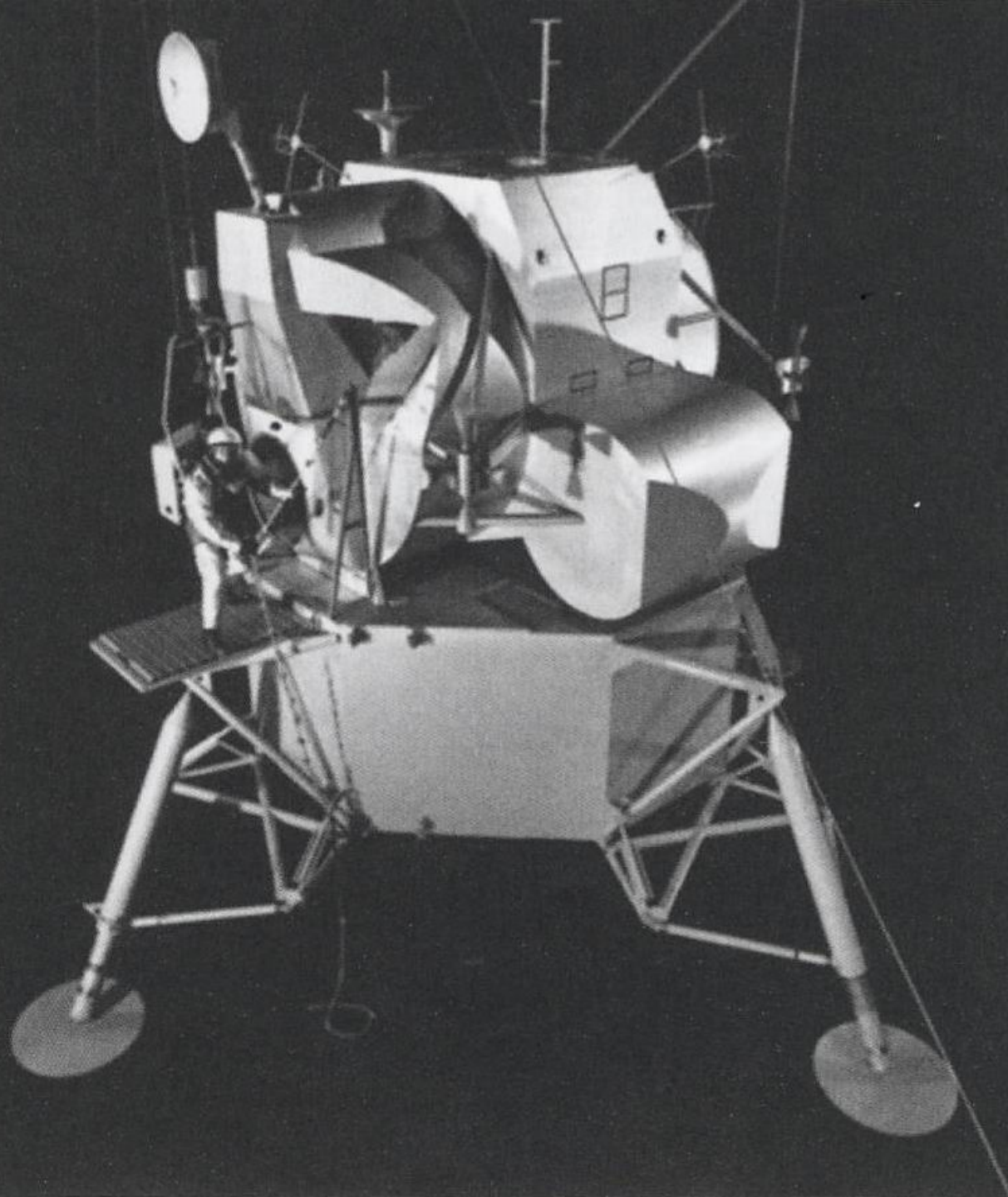

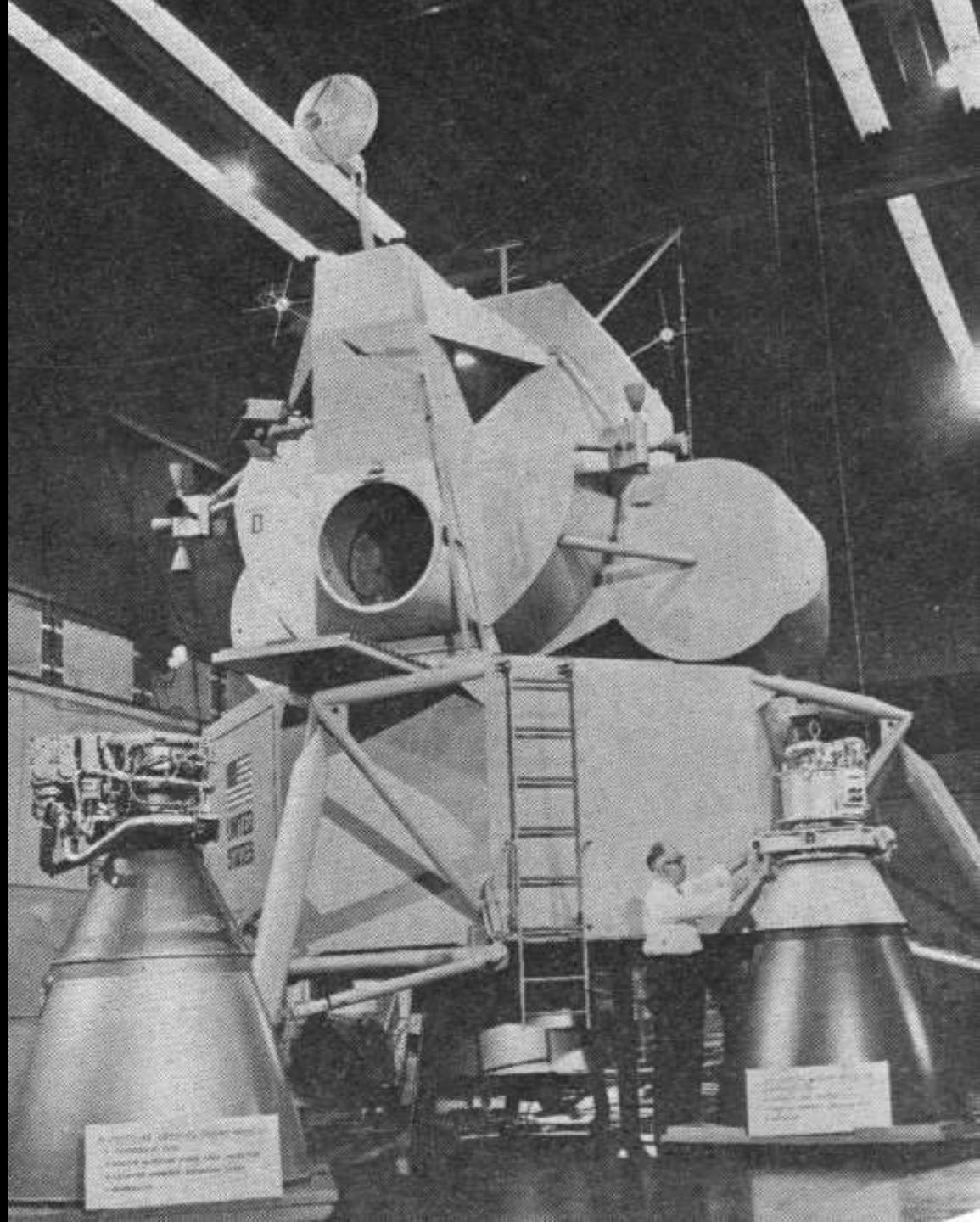

APOLLO 11 LUNAR MODULE (LM) ON DISPLAY IN THE MUSEUM OF SPACE AND FLIGHT, WASHINGTON, D.C.

APOLLO 11 LUNAR MODULE (LM) ON DISPLAY IN THE MUSEUM OF SPACE AND FLIGHT, WASHINGTON, D.C.

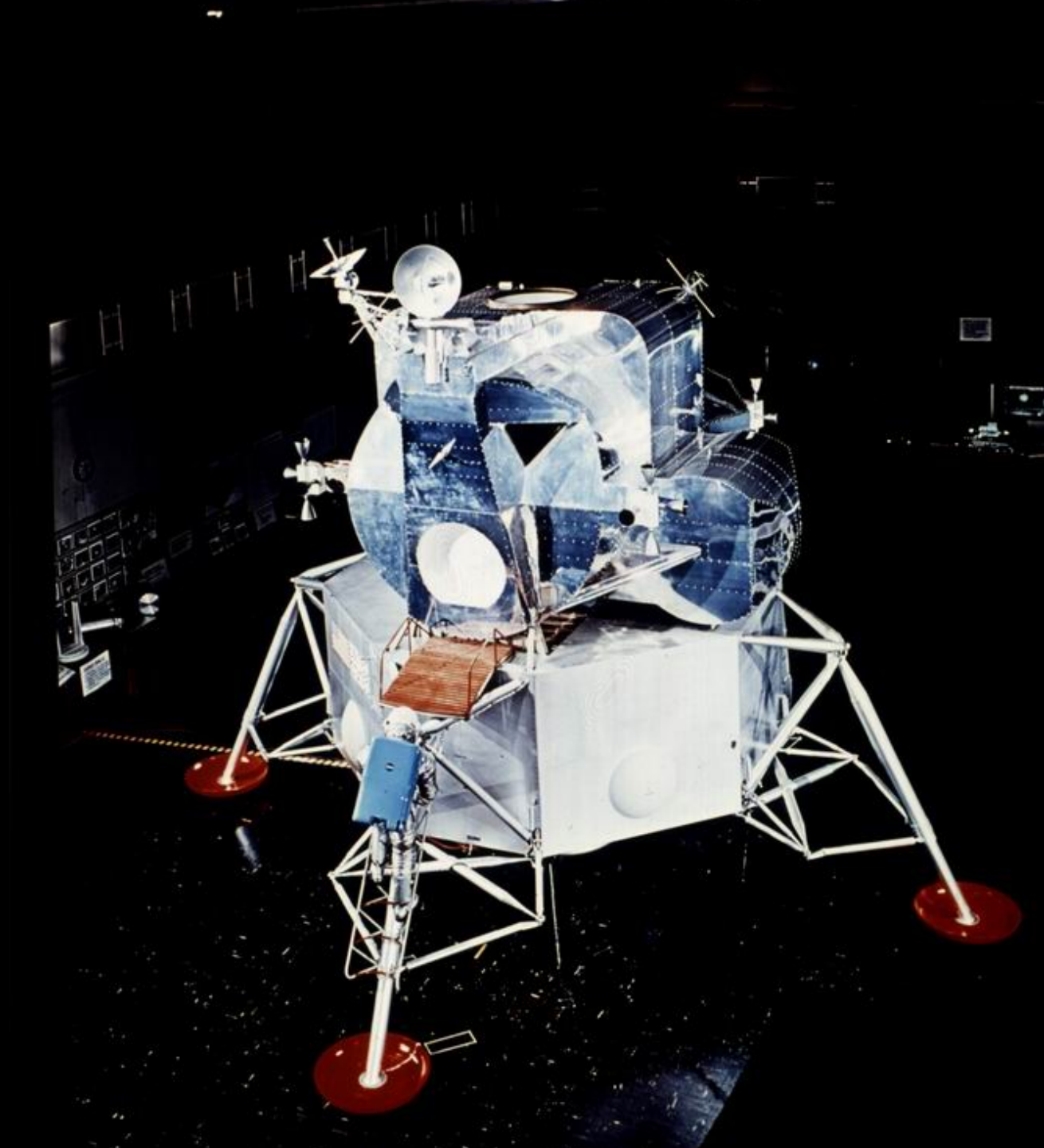





Průměr 234 cm, délka 107 cm

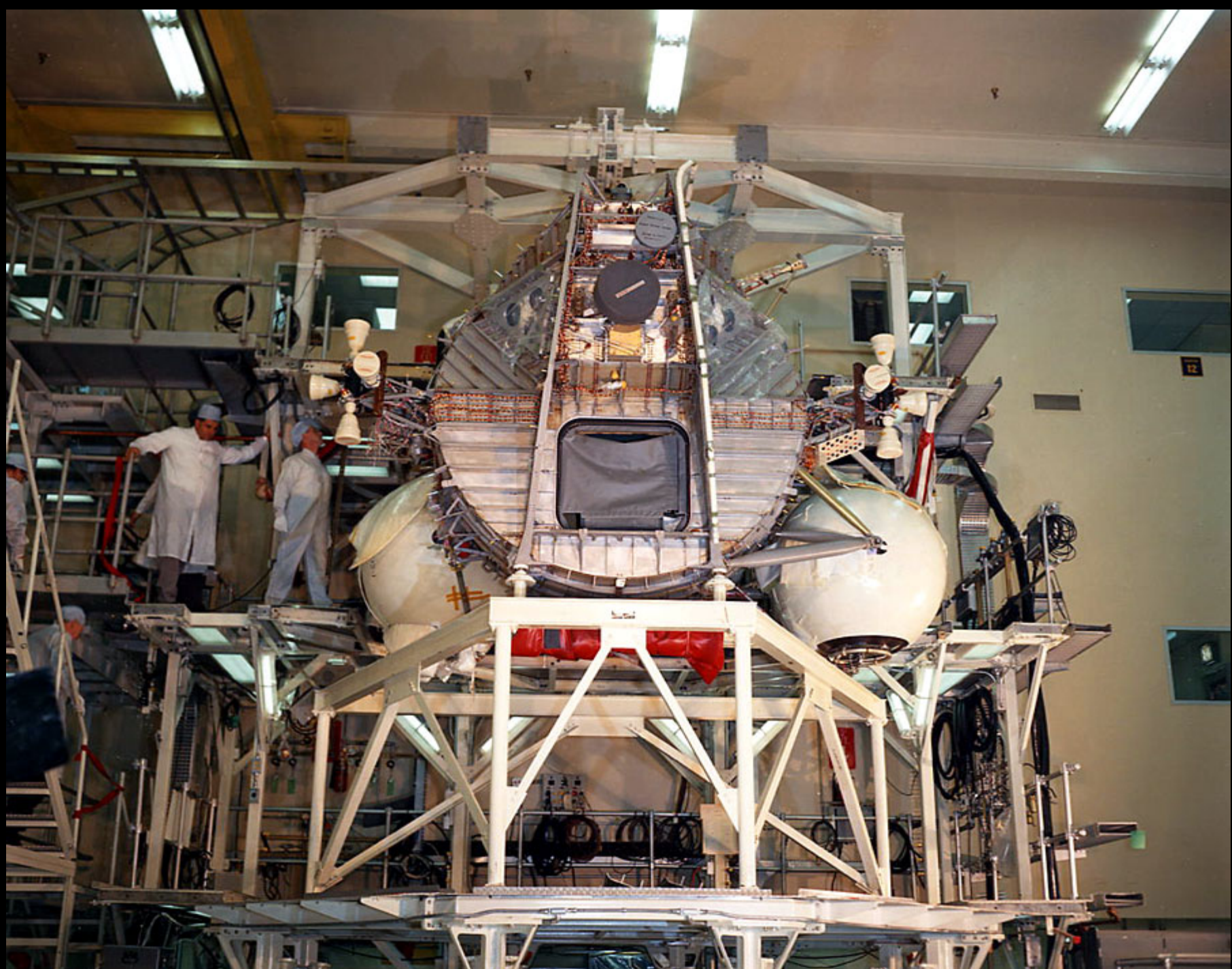





M. COLLINS
CAPTAIN

N. ARMSTRONG
C.O.

B. ALDRIN
C.O.



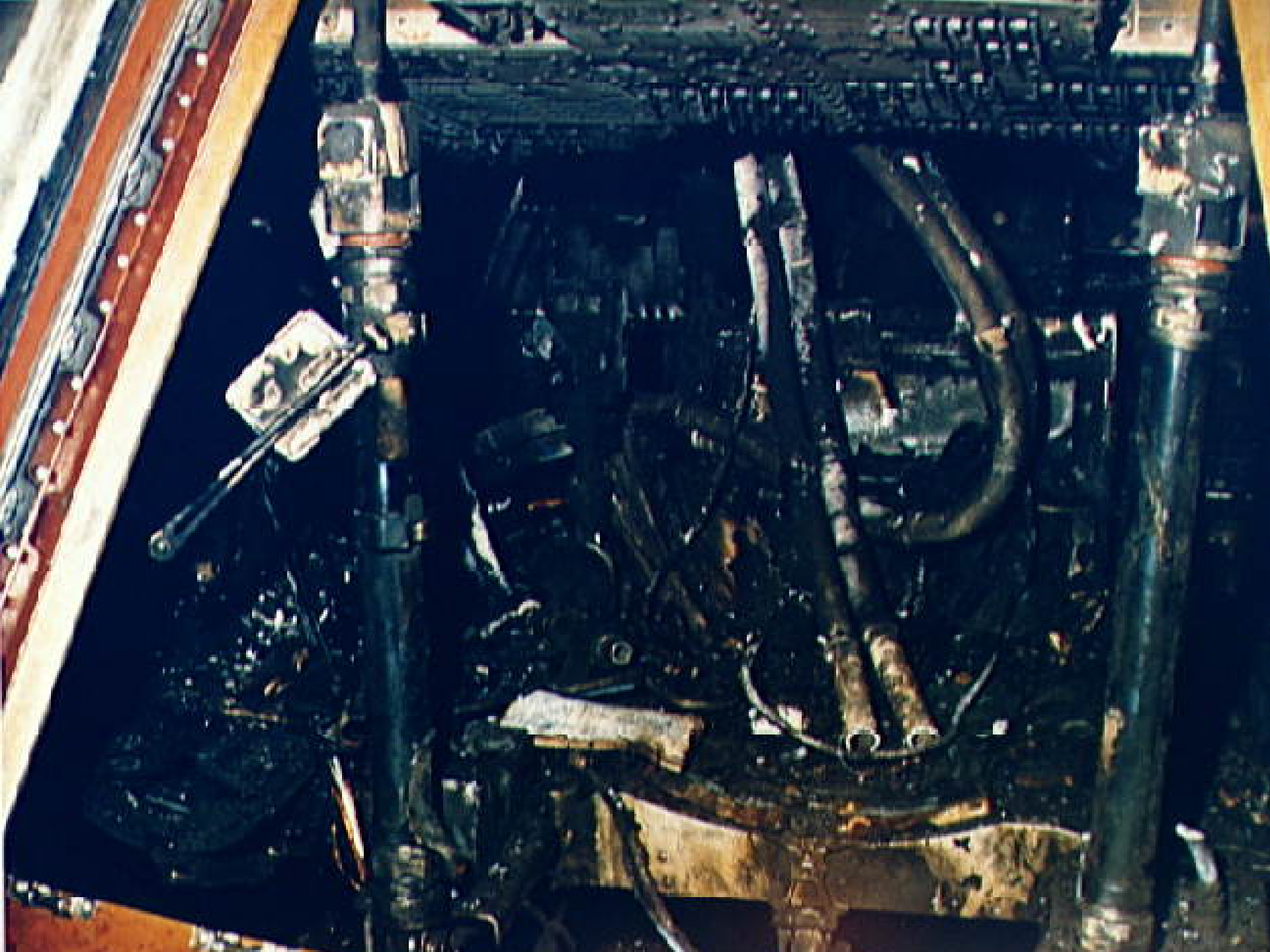

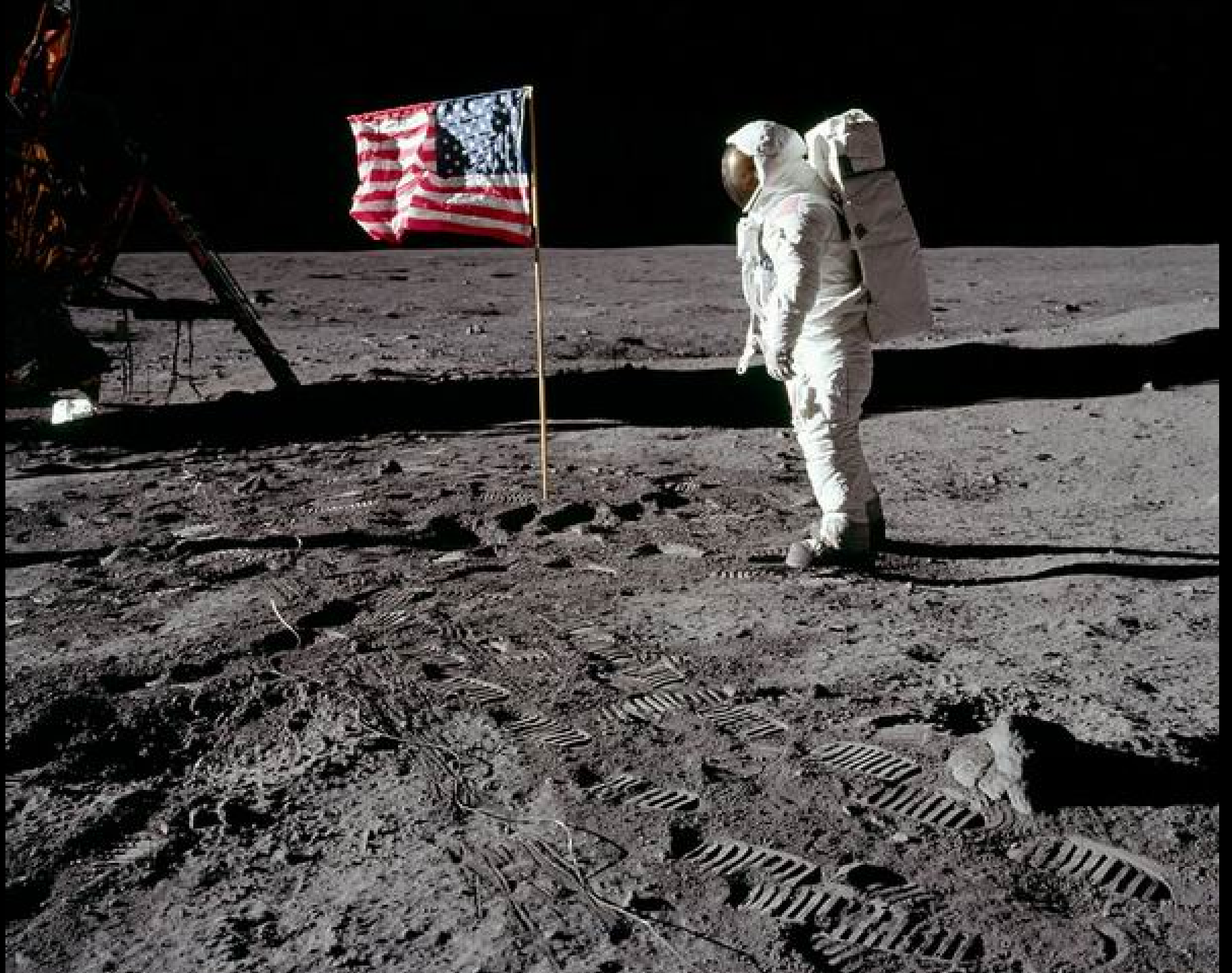

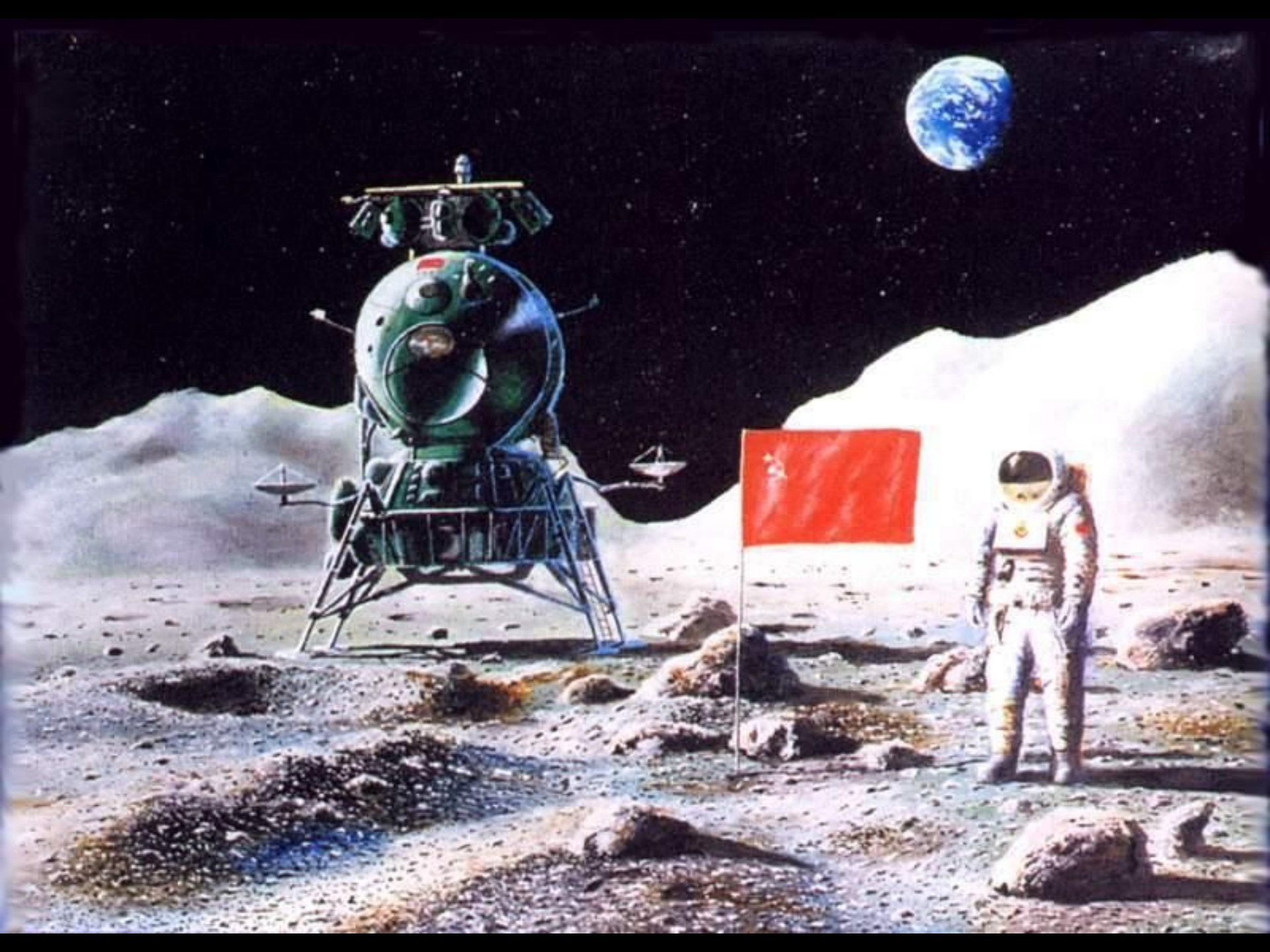

17 Aug 1958	Cancelled (Ye-1)
23 Sep 1958	Failed after 90 sec (Ye-1)
12 Oct 1958	Failure after 104 sec (Ye-1)
4 Dec 1958	Failure (Ye-1)
2 Jan 1959	First Cosmic Ship (Ye-1)
18 Jun 1959	Failure (Ye-1a)
9 Sep 1959	Pad abort (Ye-1a)
12 Sep 1959	Second Cosmic Ship (Ye-1a)
4 Oct 1959	AIS (Ye-2a)
15 Apr 1960	Failure (Ye-2f)
16 Apr 1960	Failure (Ye-2f)

17 Aug 1958	Cancelled (Ye-1)
23 Sep 1958	Failed after 90 sec (Ye-1)
12 Oct 1958	Failure after 104 sec (Ye-1)
4 Dec 1958	Failure (Ye-1)
2 Jan 1959	First Cosmic Ship (Ye-1)
18 Jun 1959	Failure (Ye-1a)
9 Sep 1959	Pad abort (Ye-1a)
12 Sep 1959	Second Cosmic Ship (Ye-1a)
4 Oct 1959	AIS (Ye-2a)
15 Apr 1960	Failure (Ye-2f)
16 Apr 1960	Failure (Ye-2f)

Plány 1963

L-1: Pilotovaný oblet
Měsíce.

L-2: Automatické lunární
vozidlo.

L-3: Pilotované přistání
na Měsíci.

L-4: Lunární orbitální
stanice.

L-5: Lunární vozidlo s
posádkou.

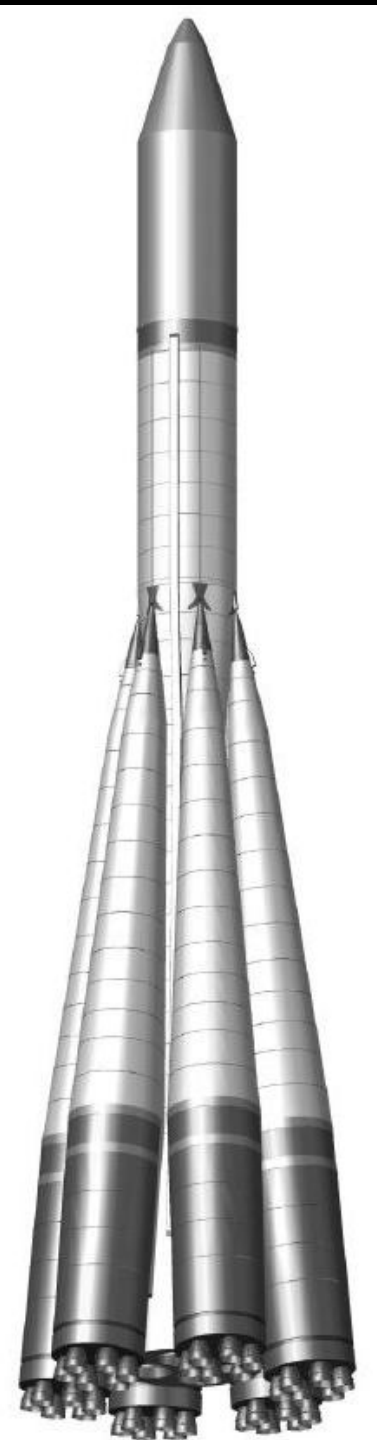

L-2: lunární vozidlo

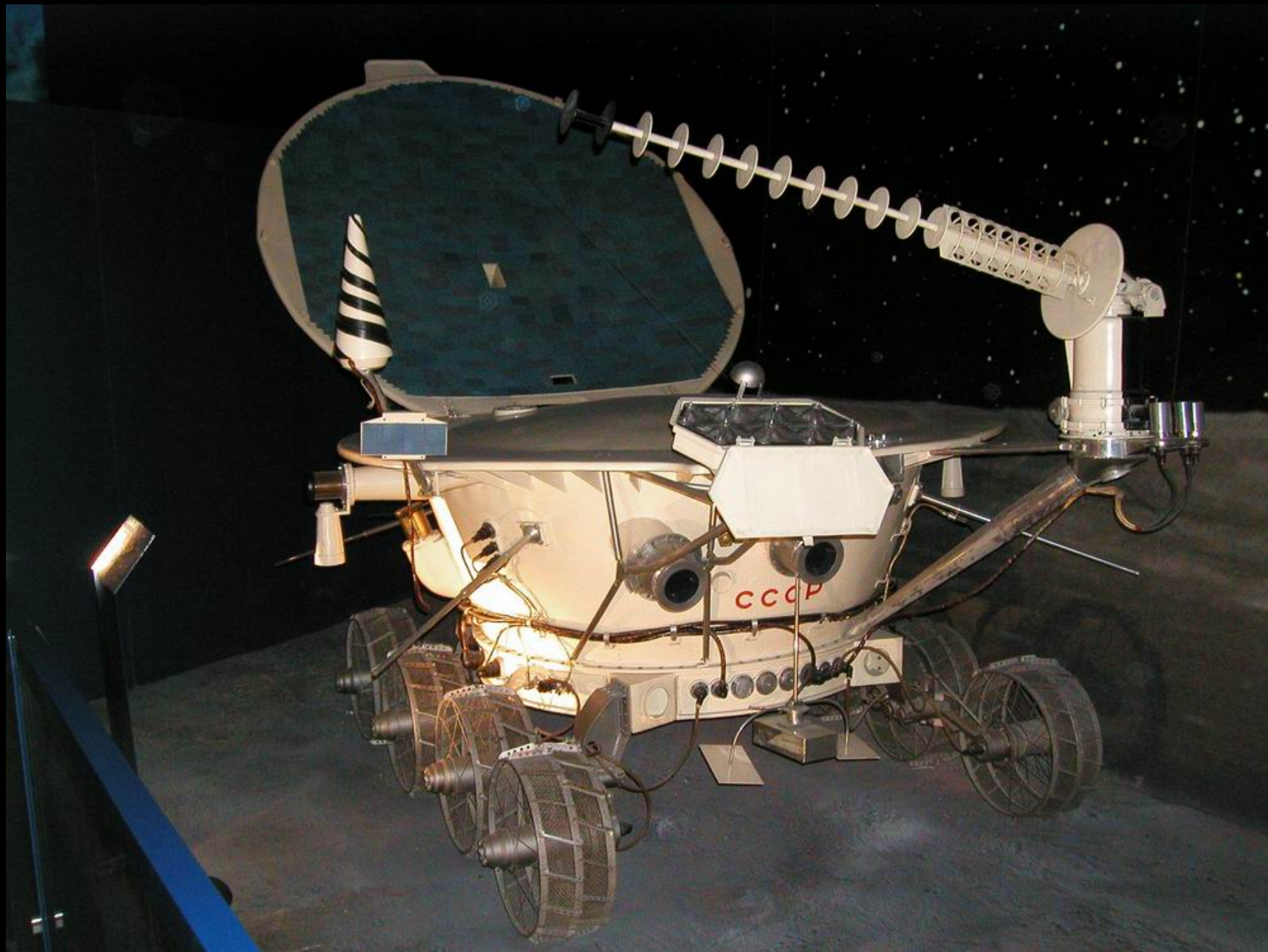



1964 až 67 vývoj

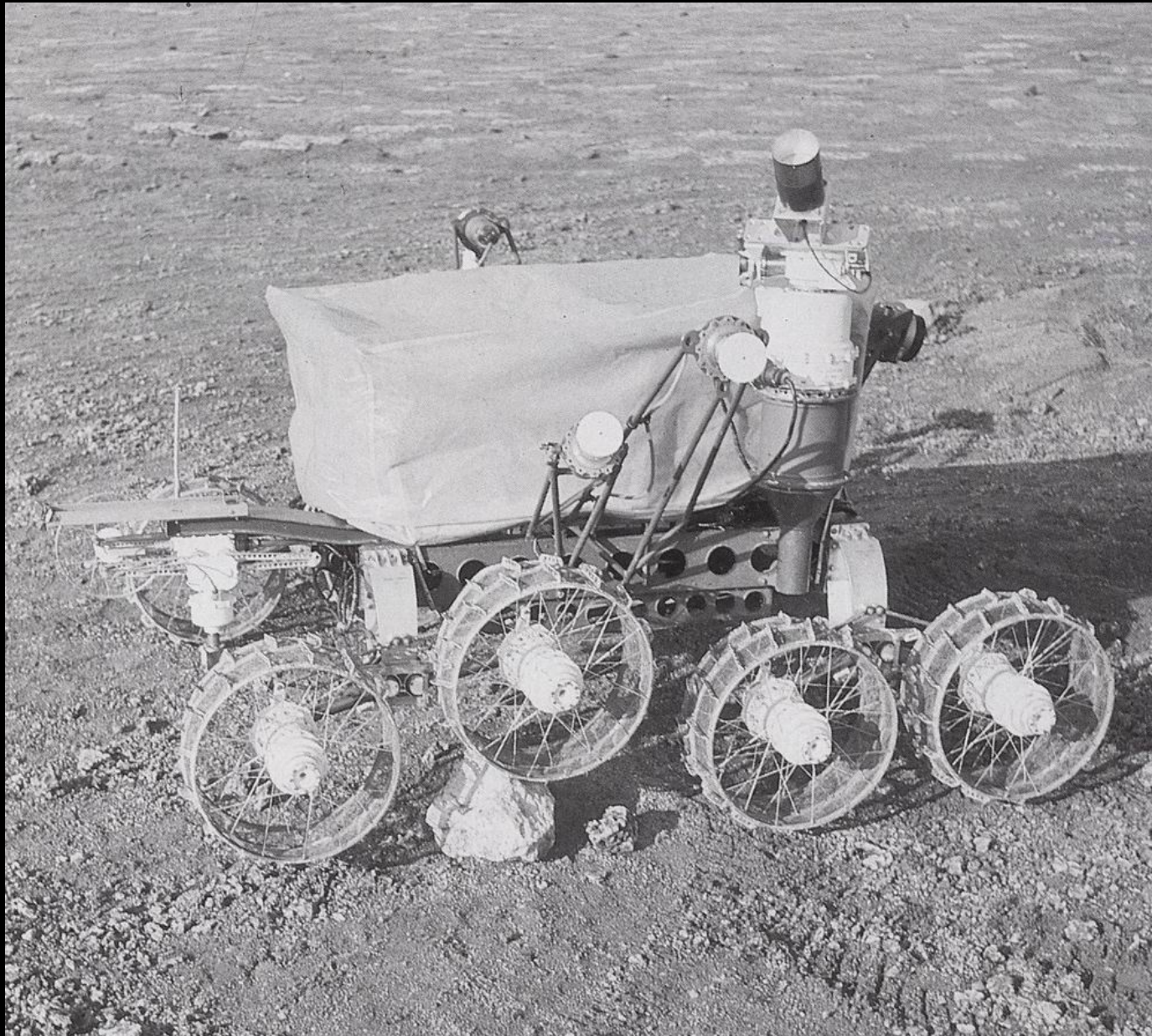



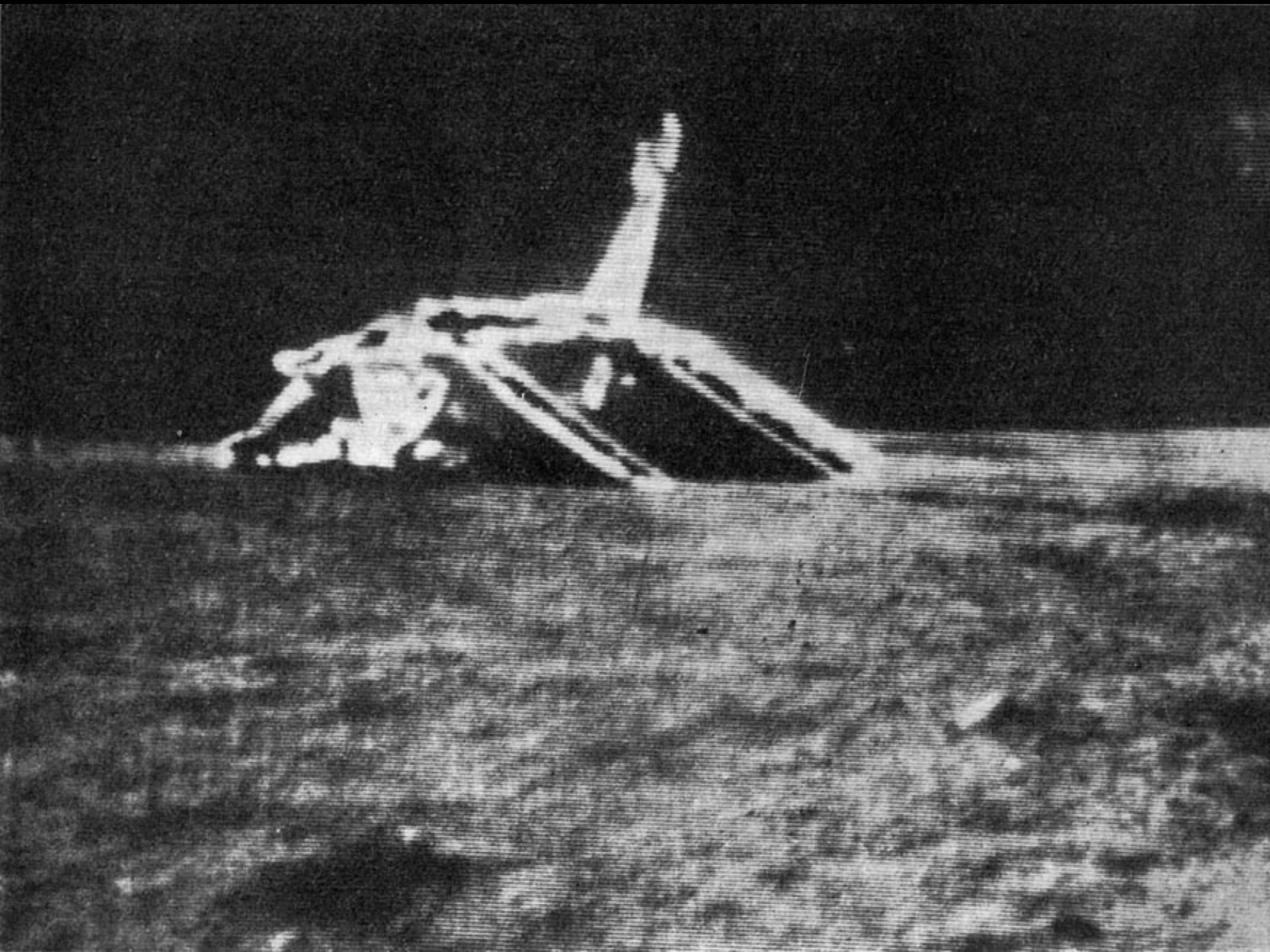

„Nenechávejme Měsíc Američanům!“



3. srpna 1964 – dekret 655-268

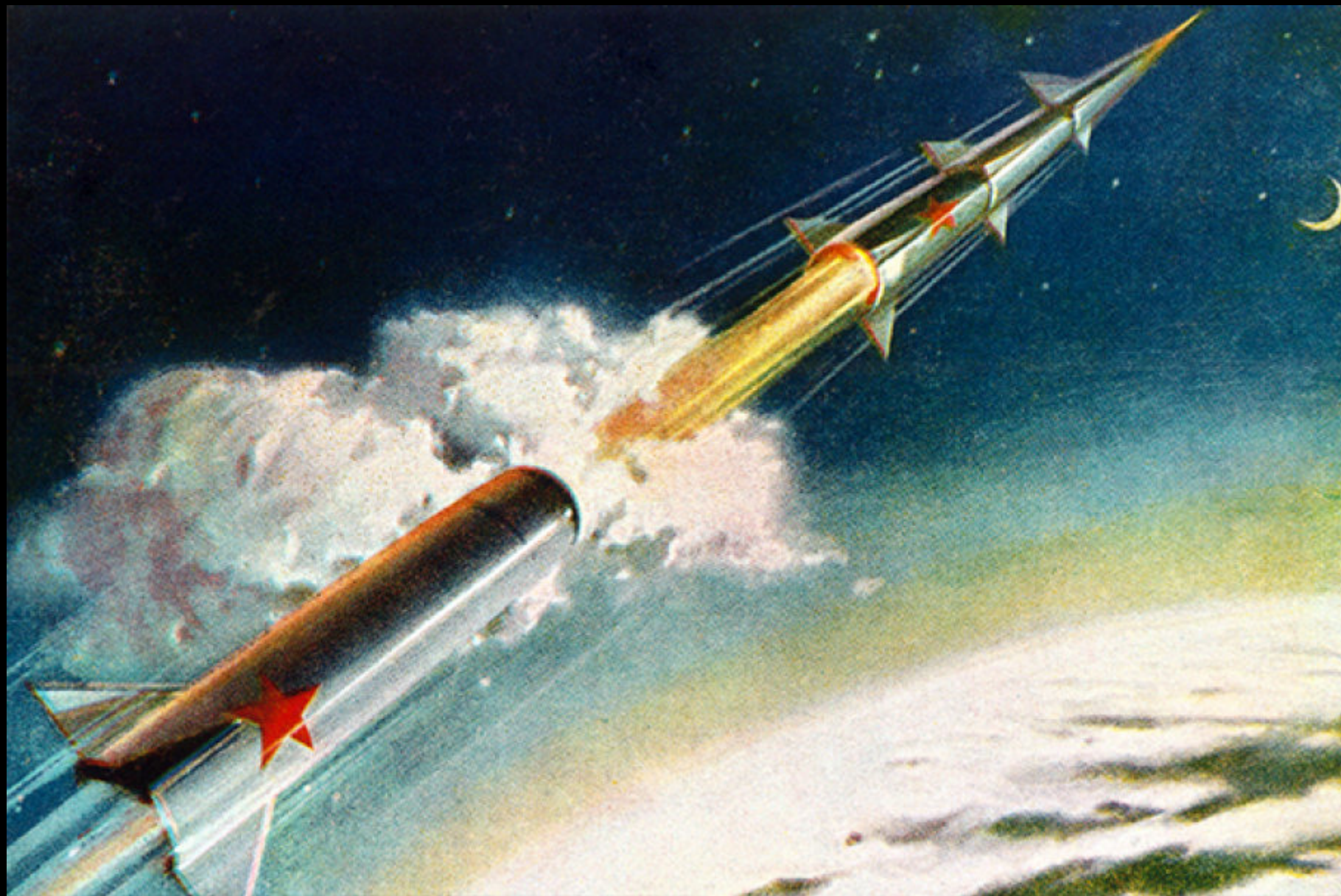

Program L-1

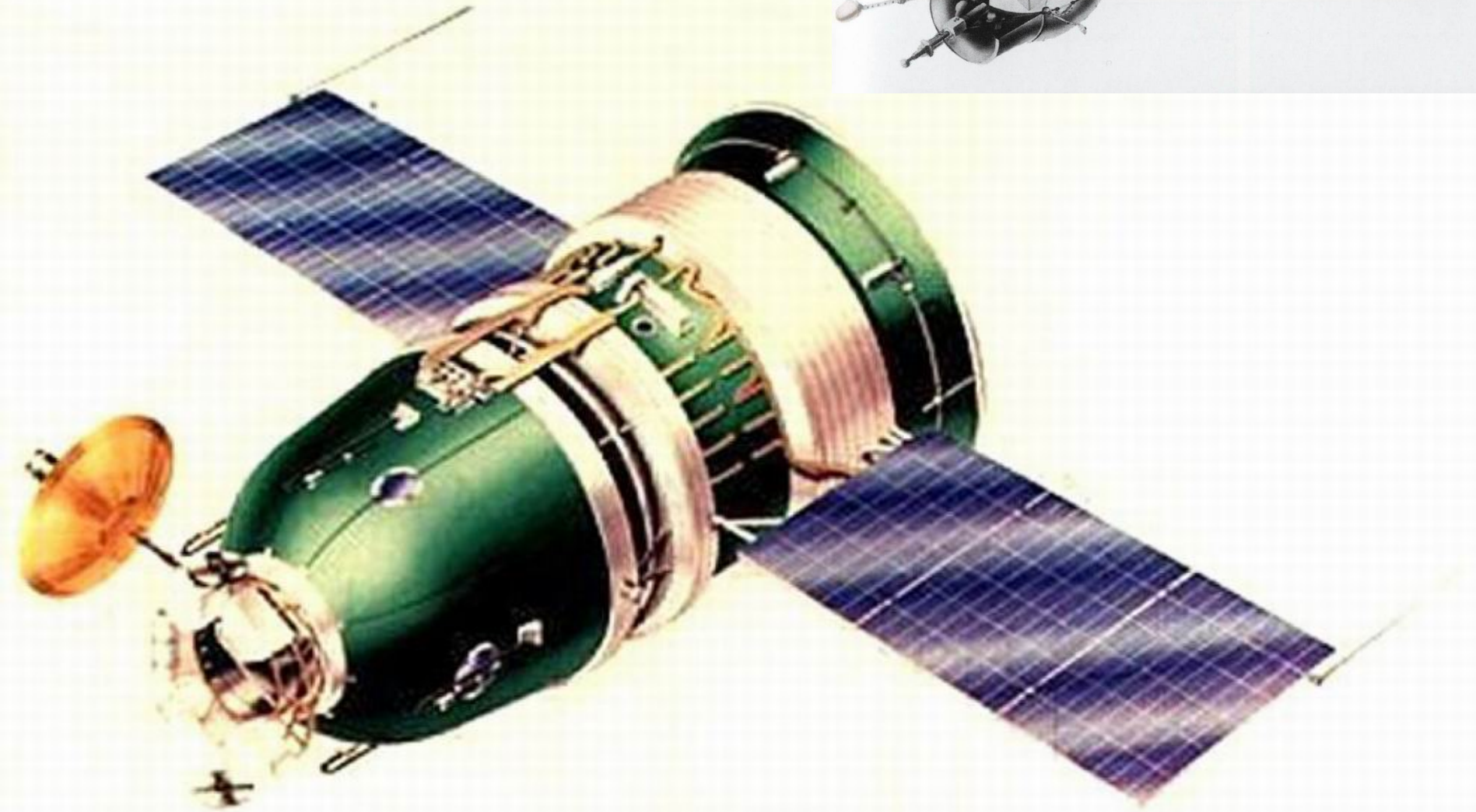
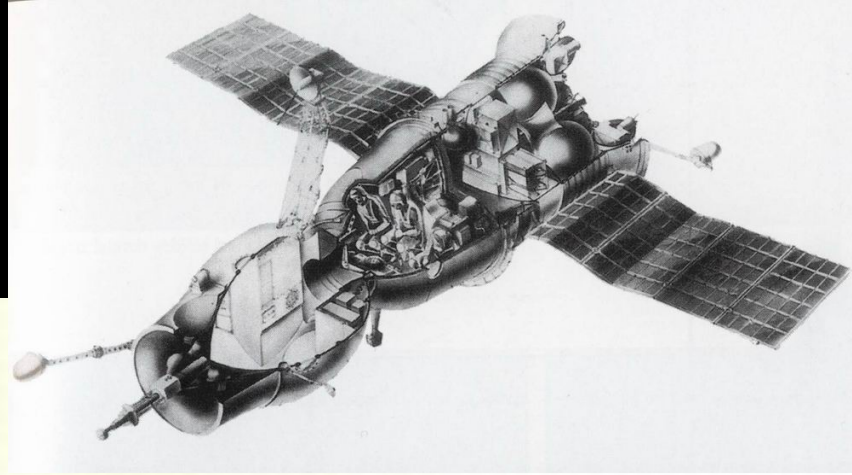

15. září 1968, Zond 5

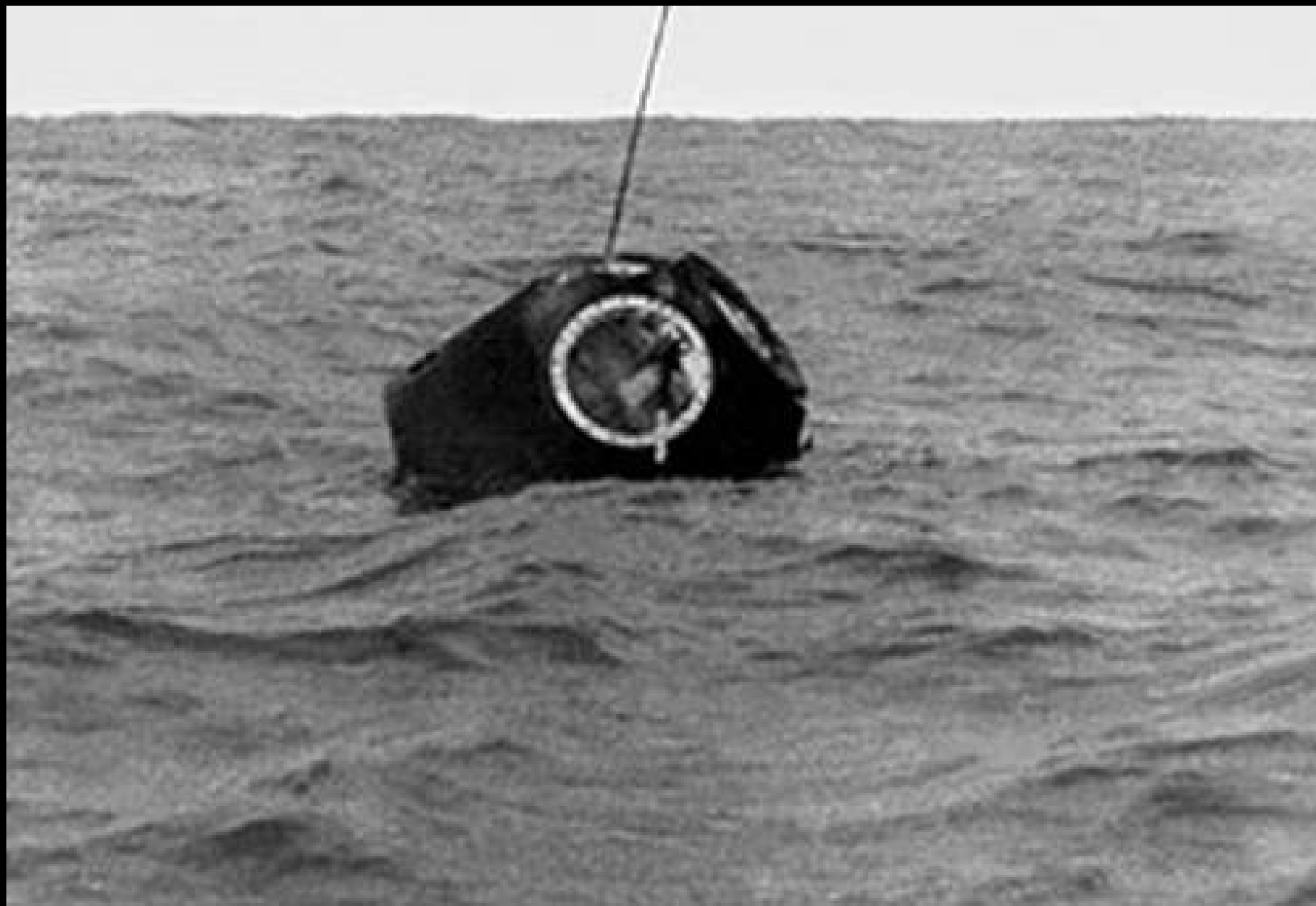



Program L-3/N-1

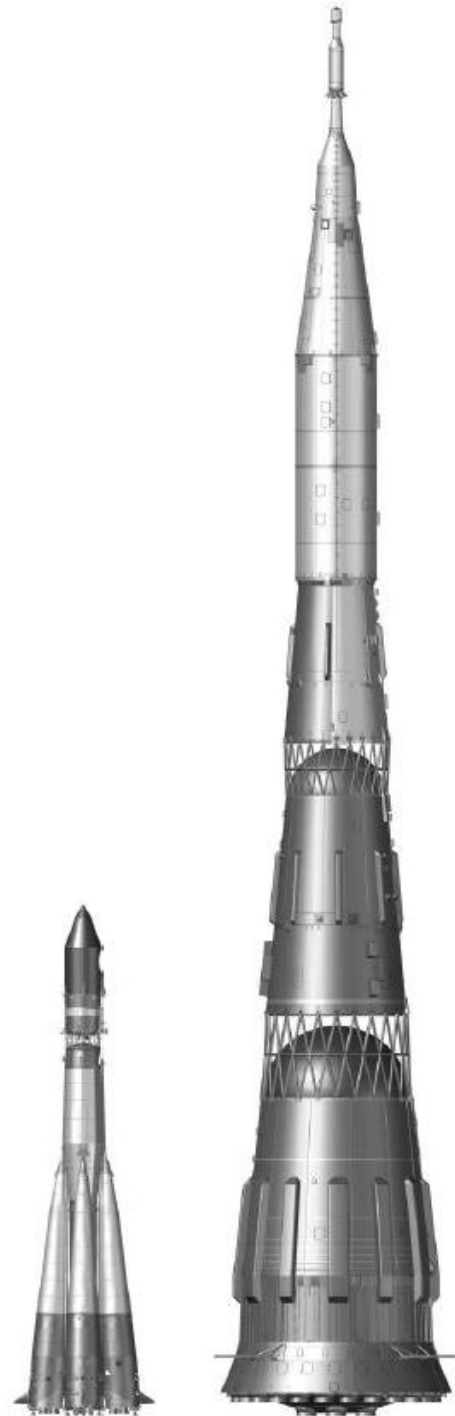
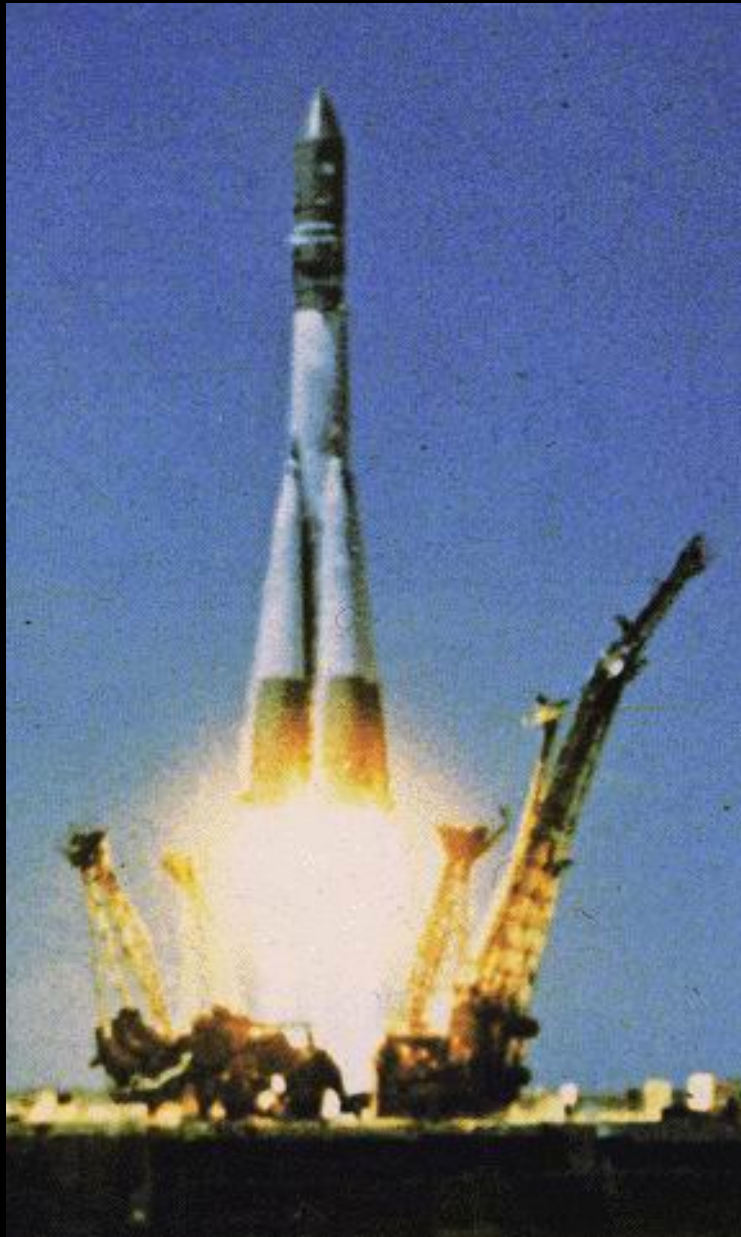

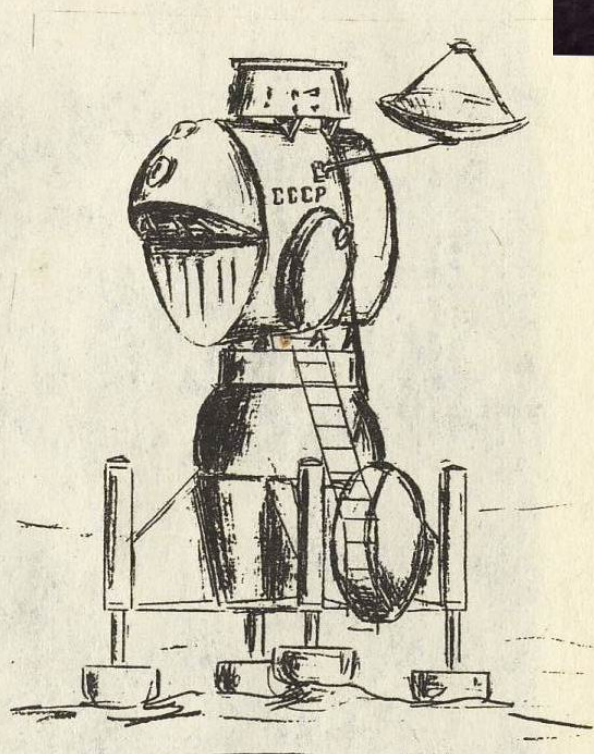
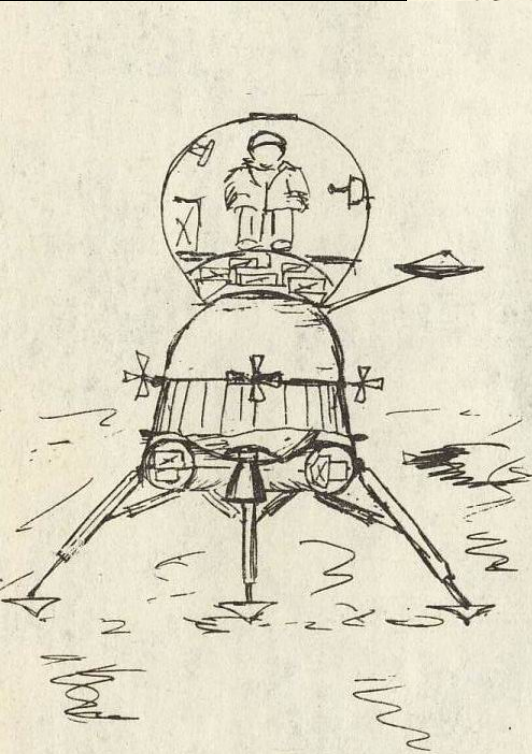
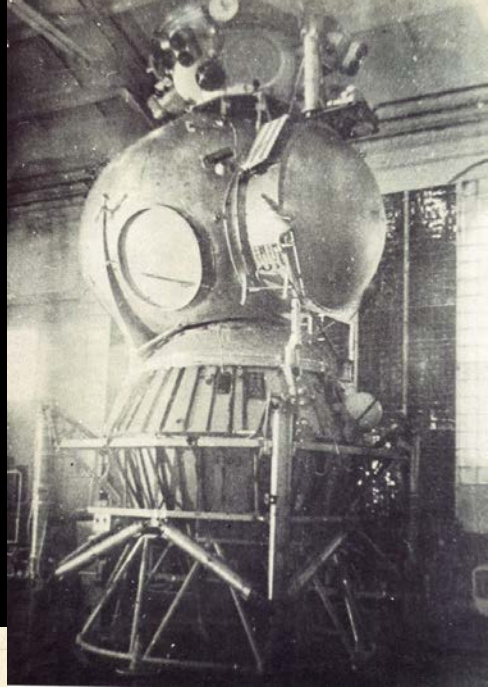
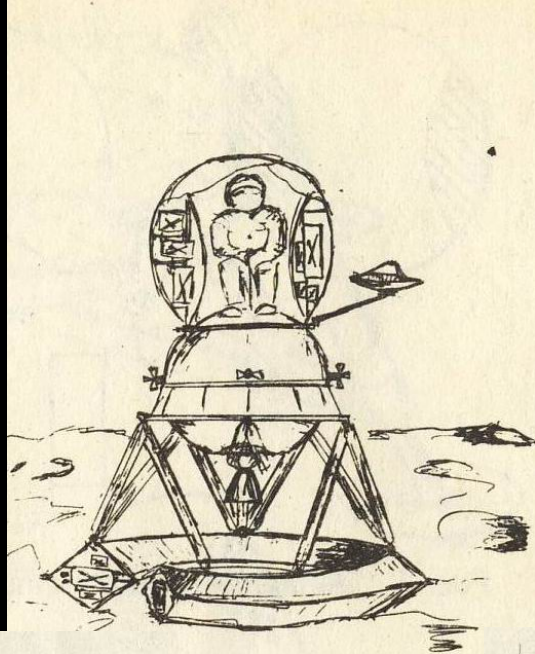

1965+



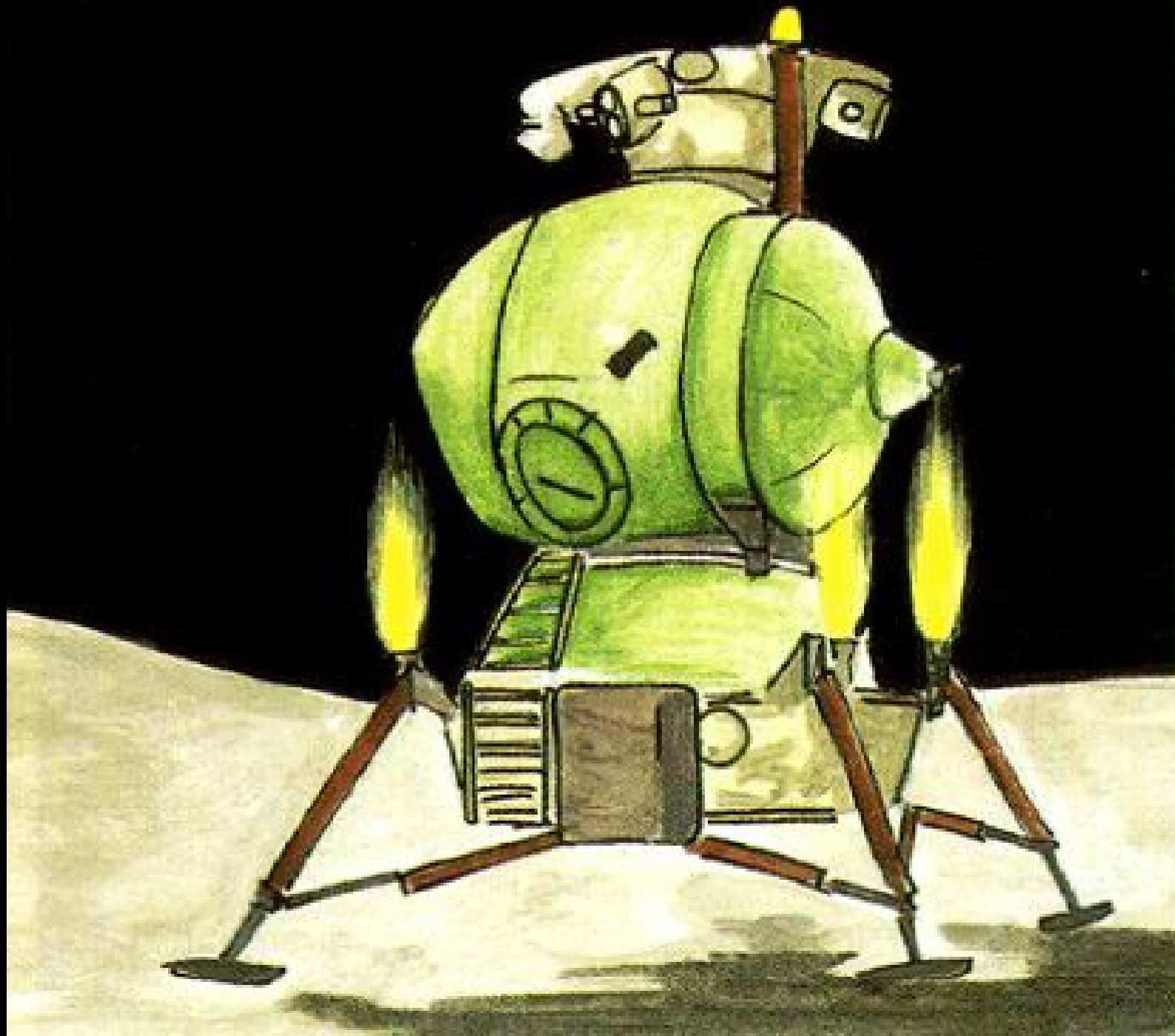

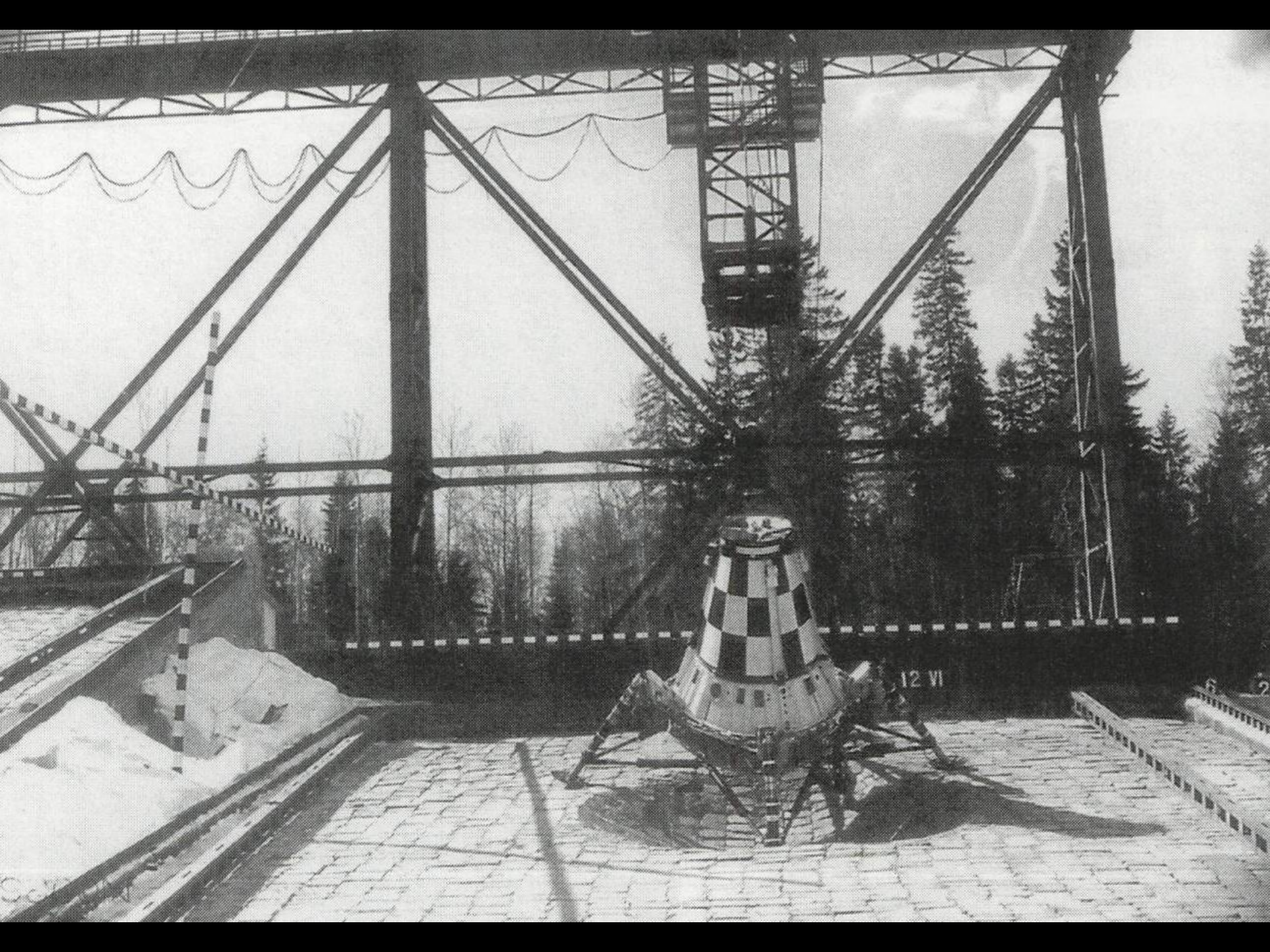

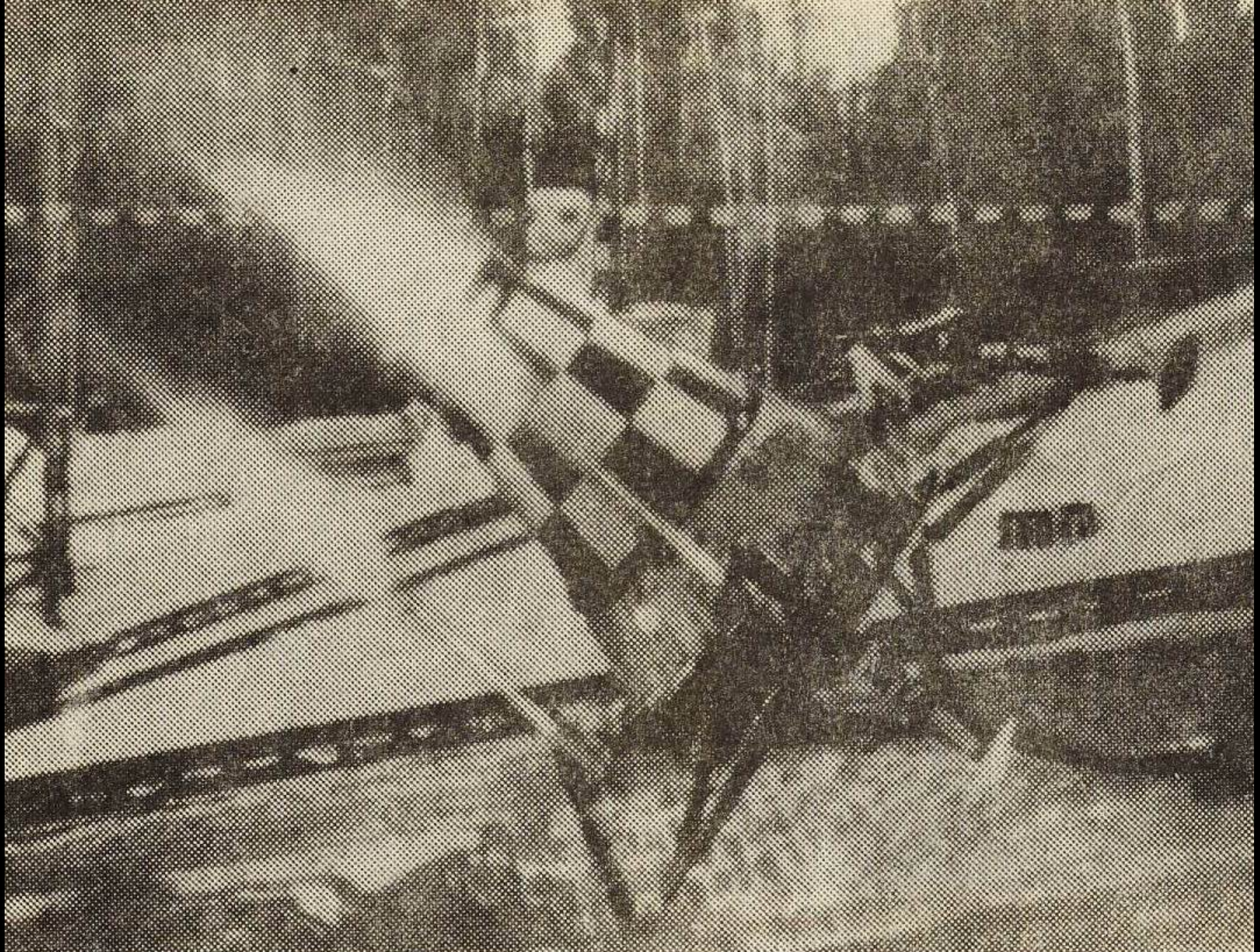

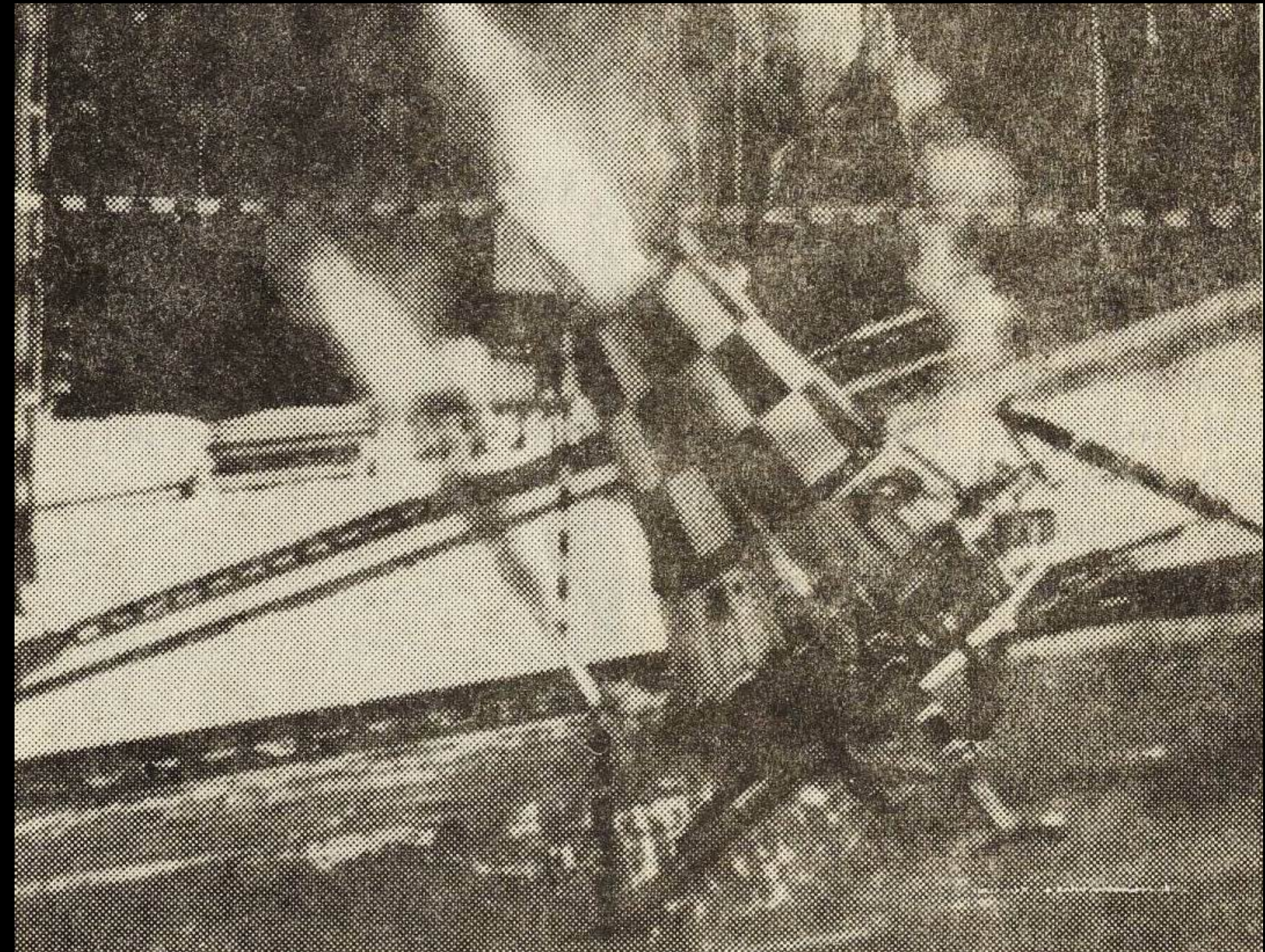

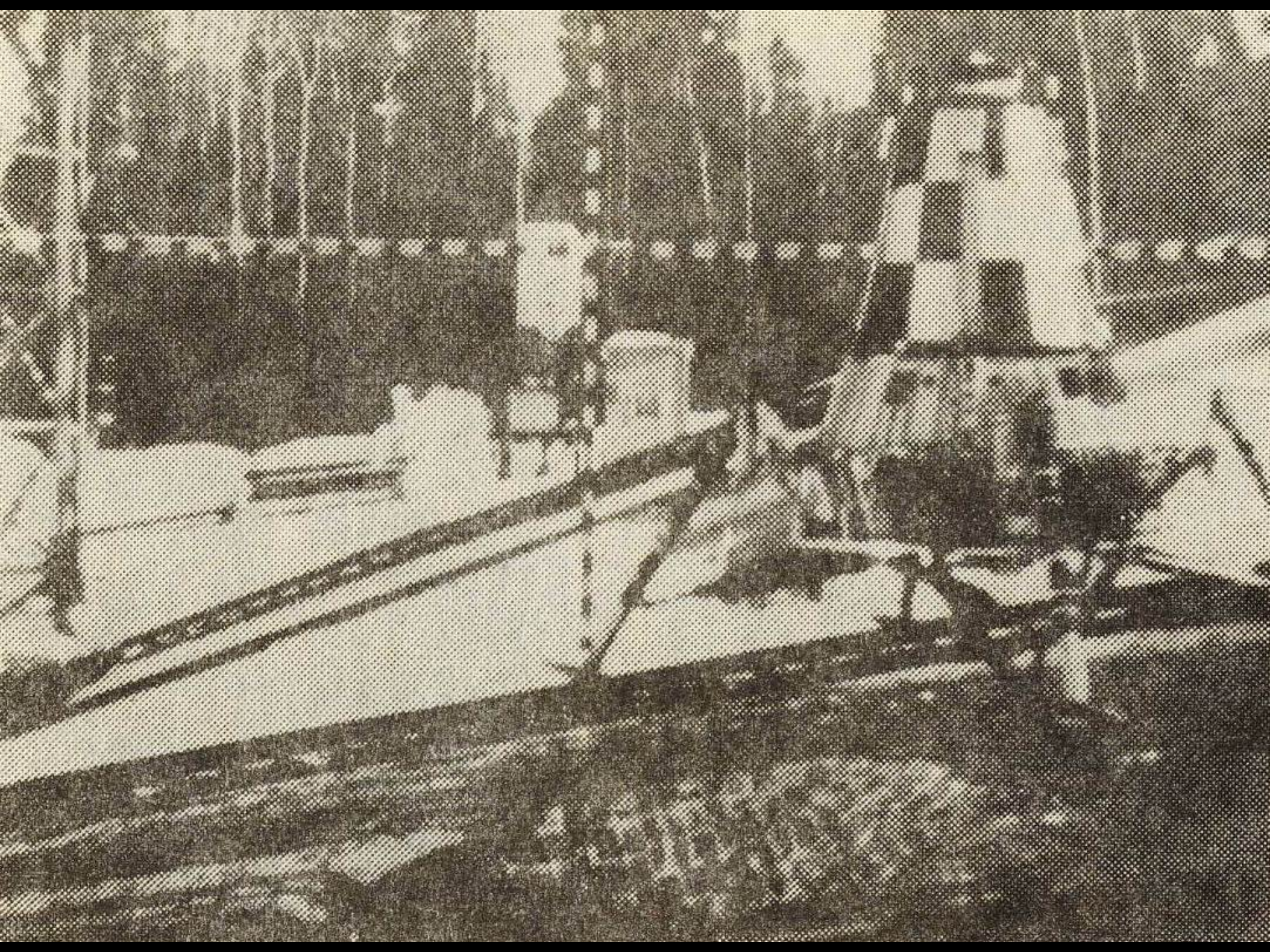

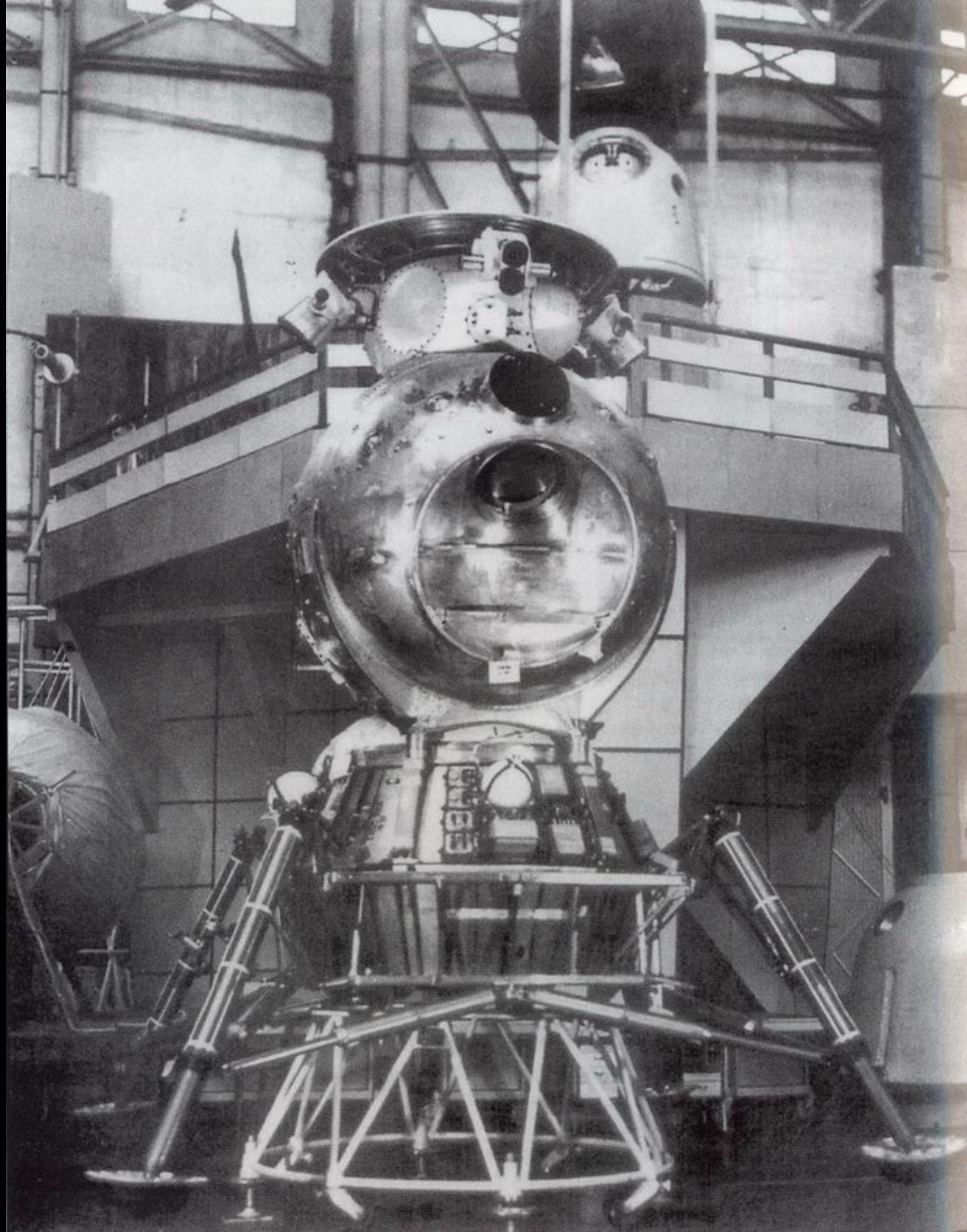

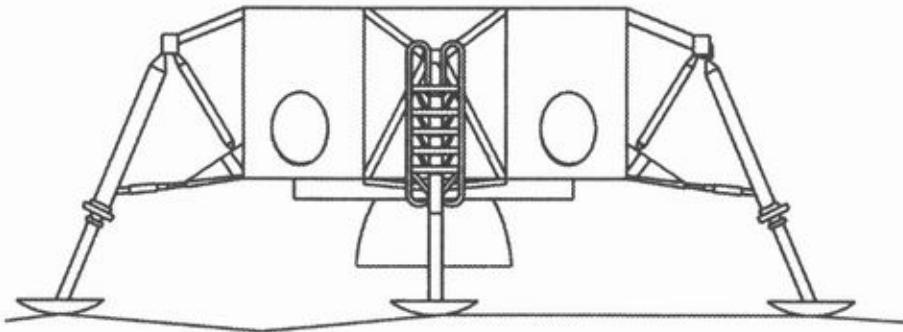
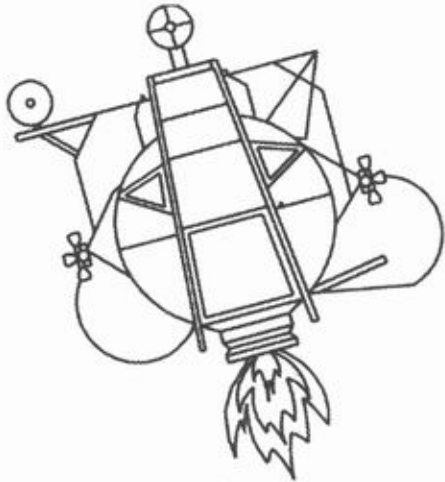

LM

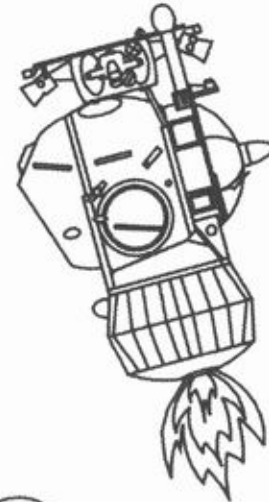

Block E

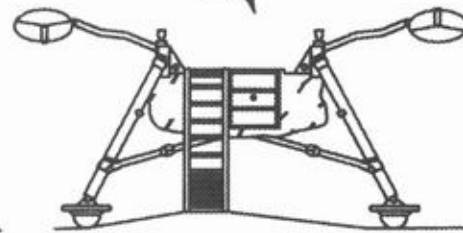

LK

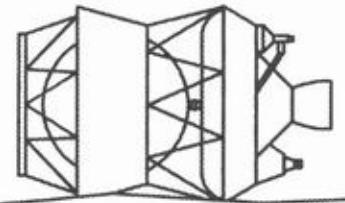

Block D

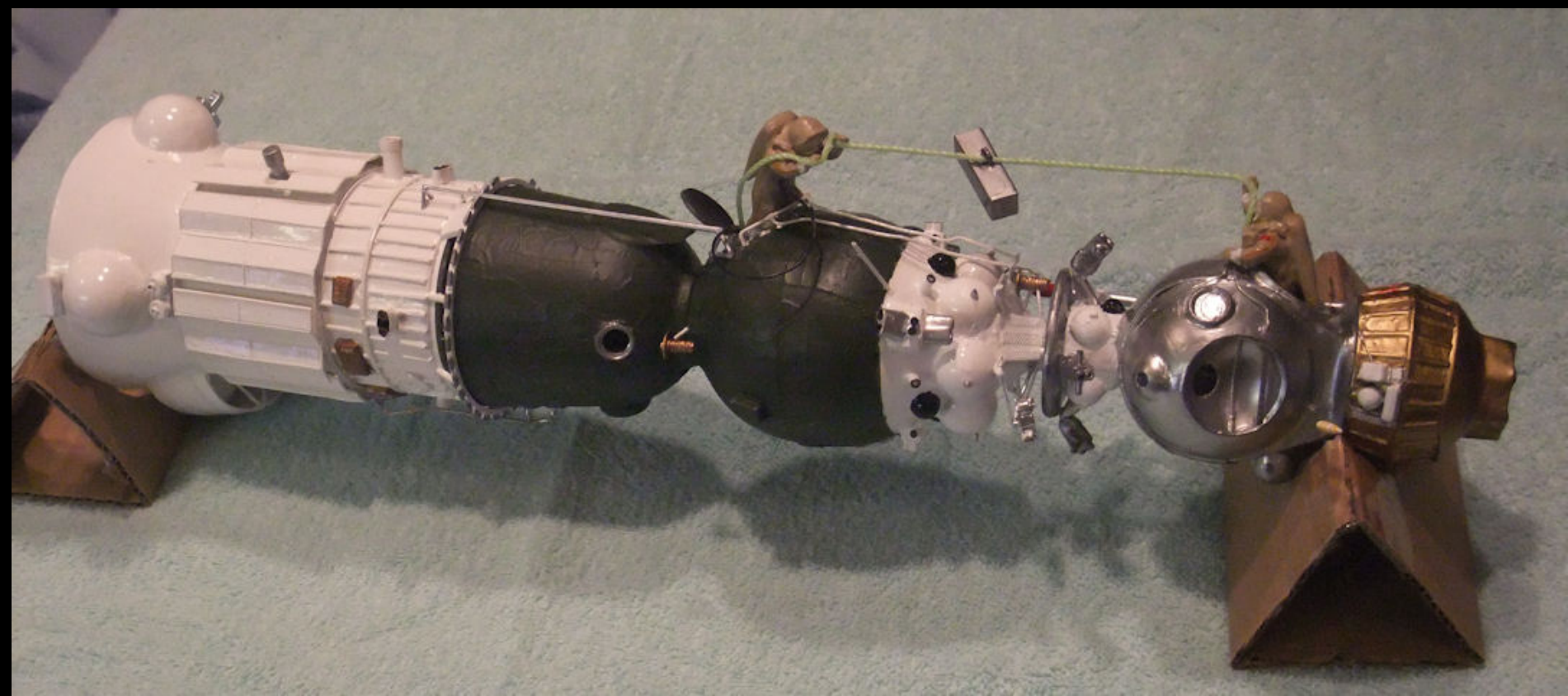

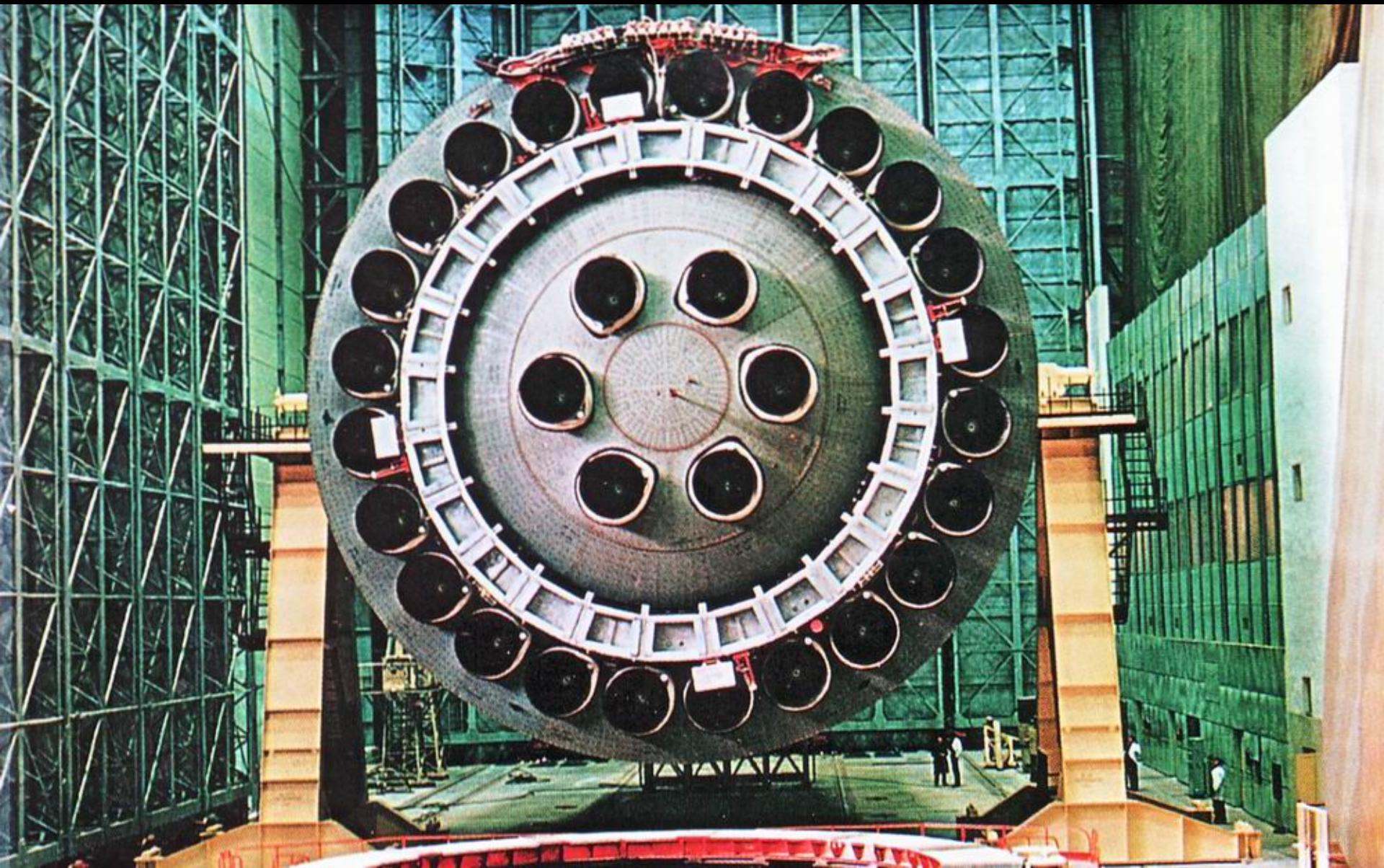

21. února 1969 - START!



3. července 1969 - START!













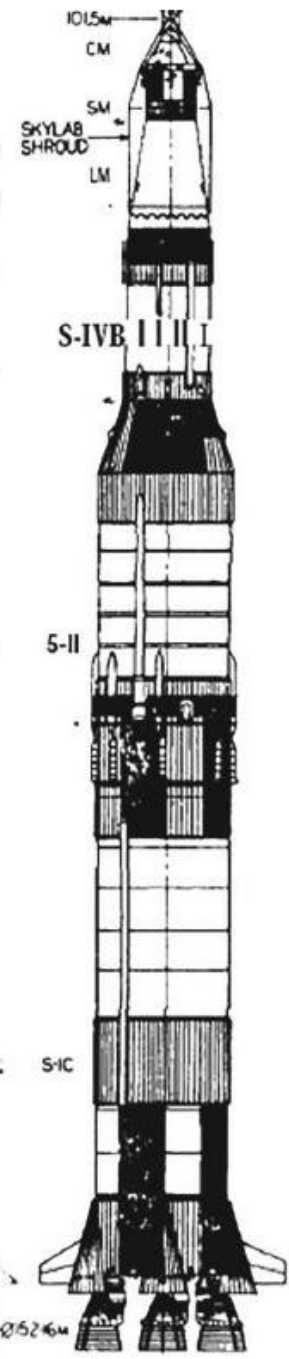
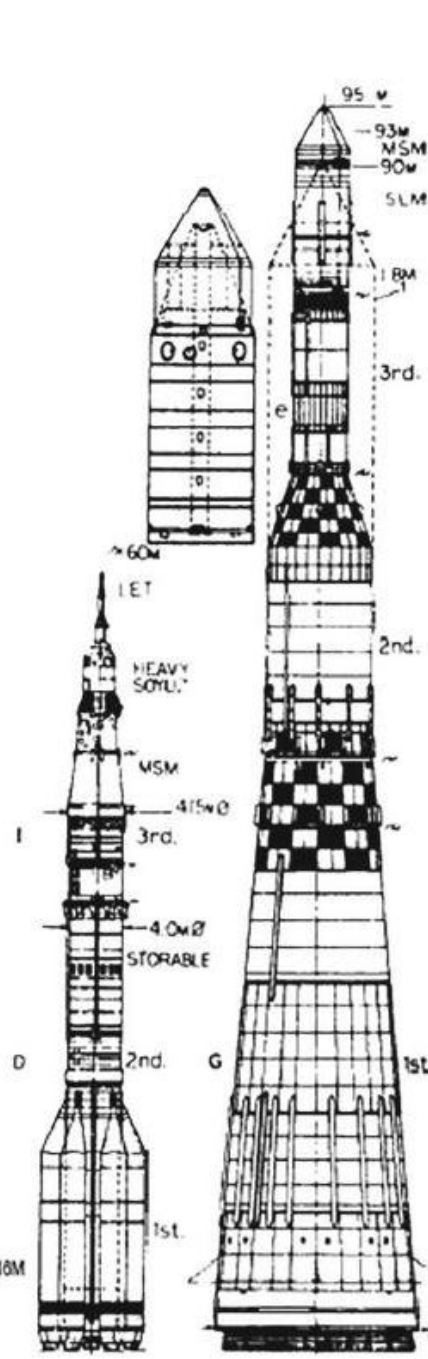
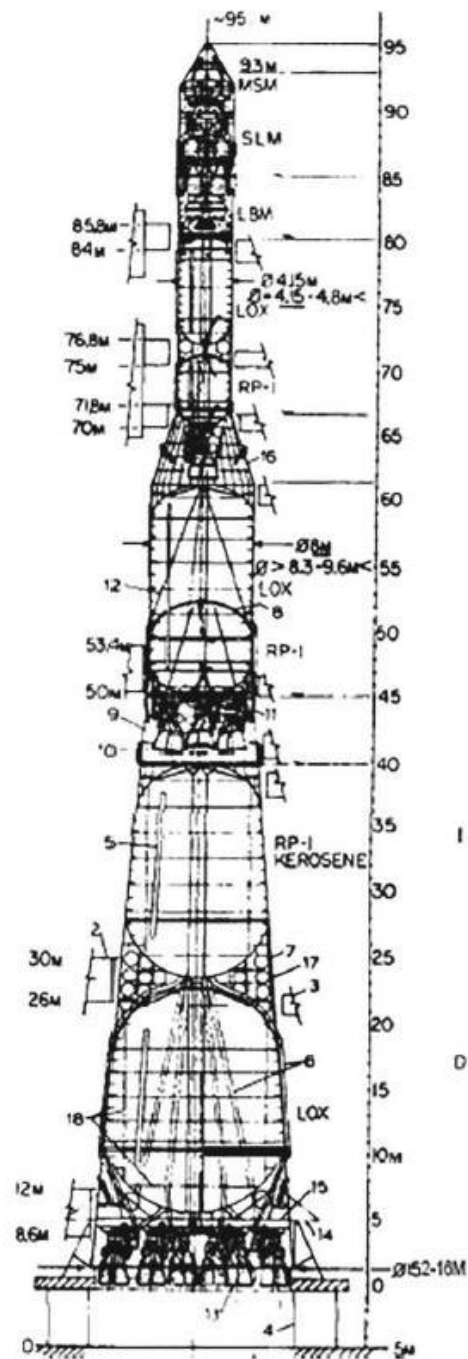

21. června 1971 - START!

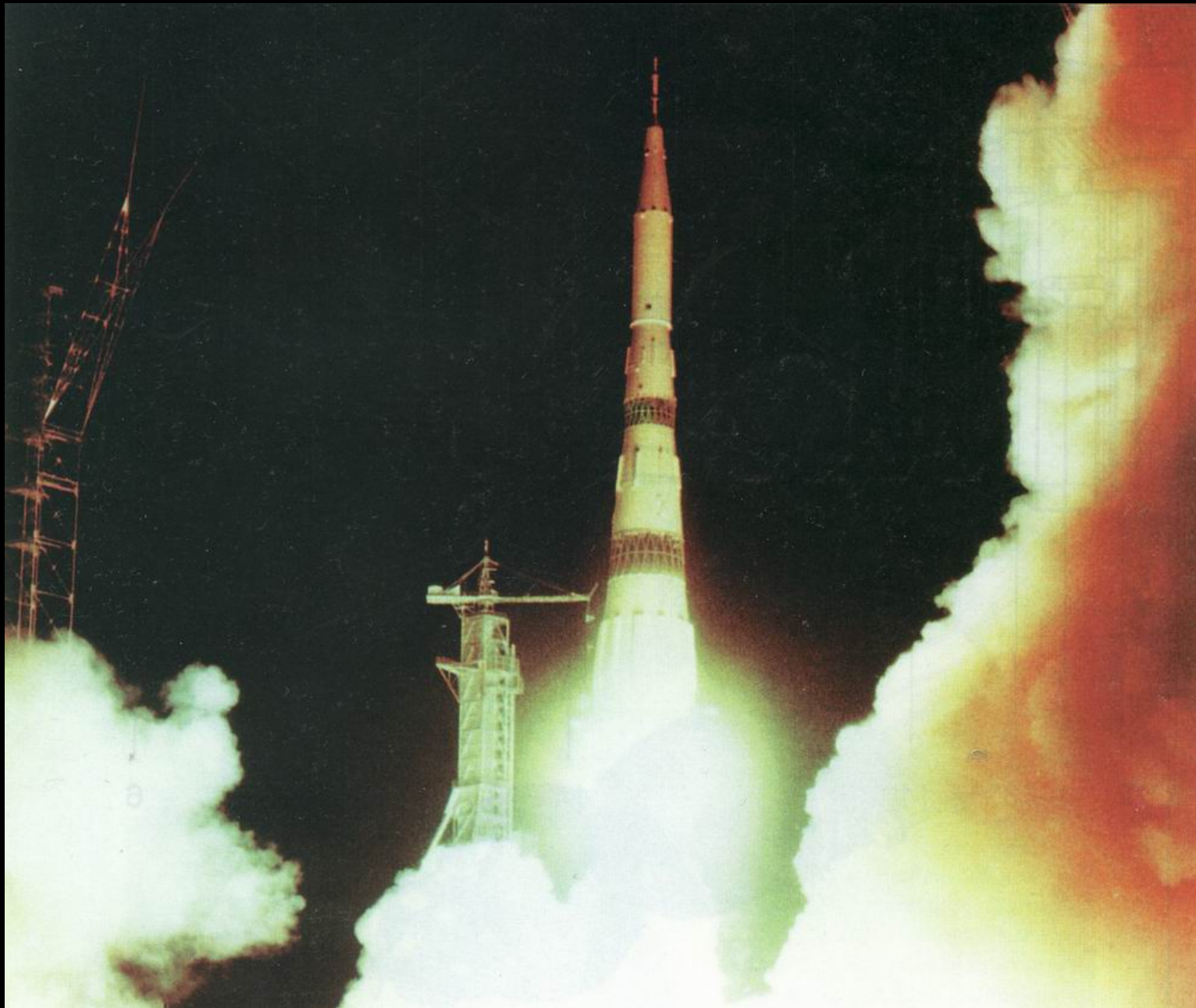

23. listopadu 1972 - START!

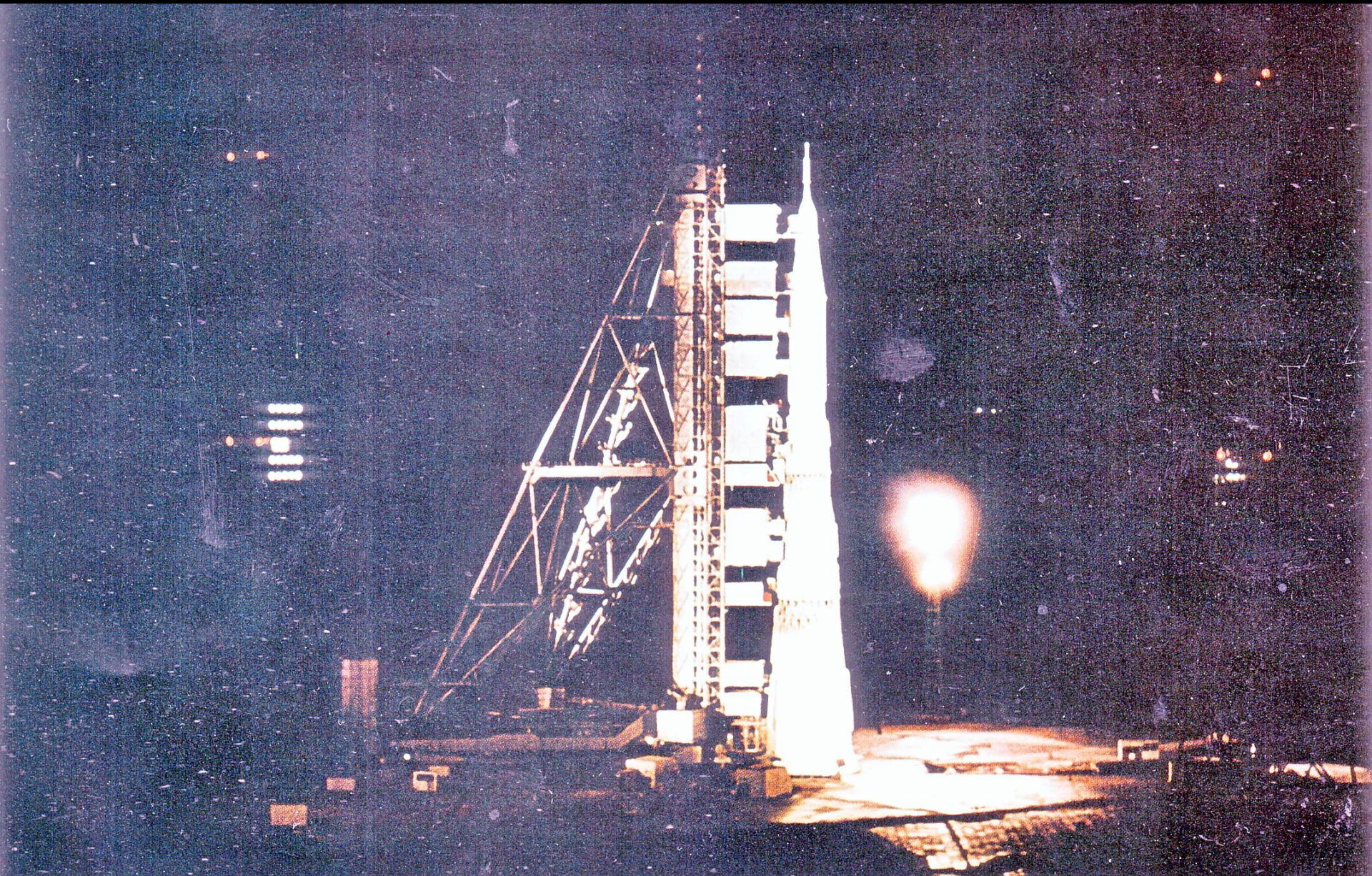

Srpen a listopad 1974

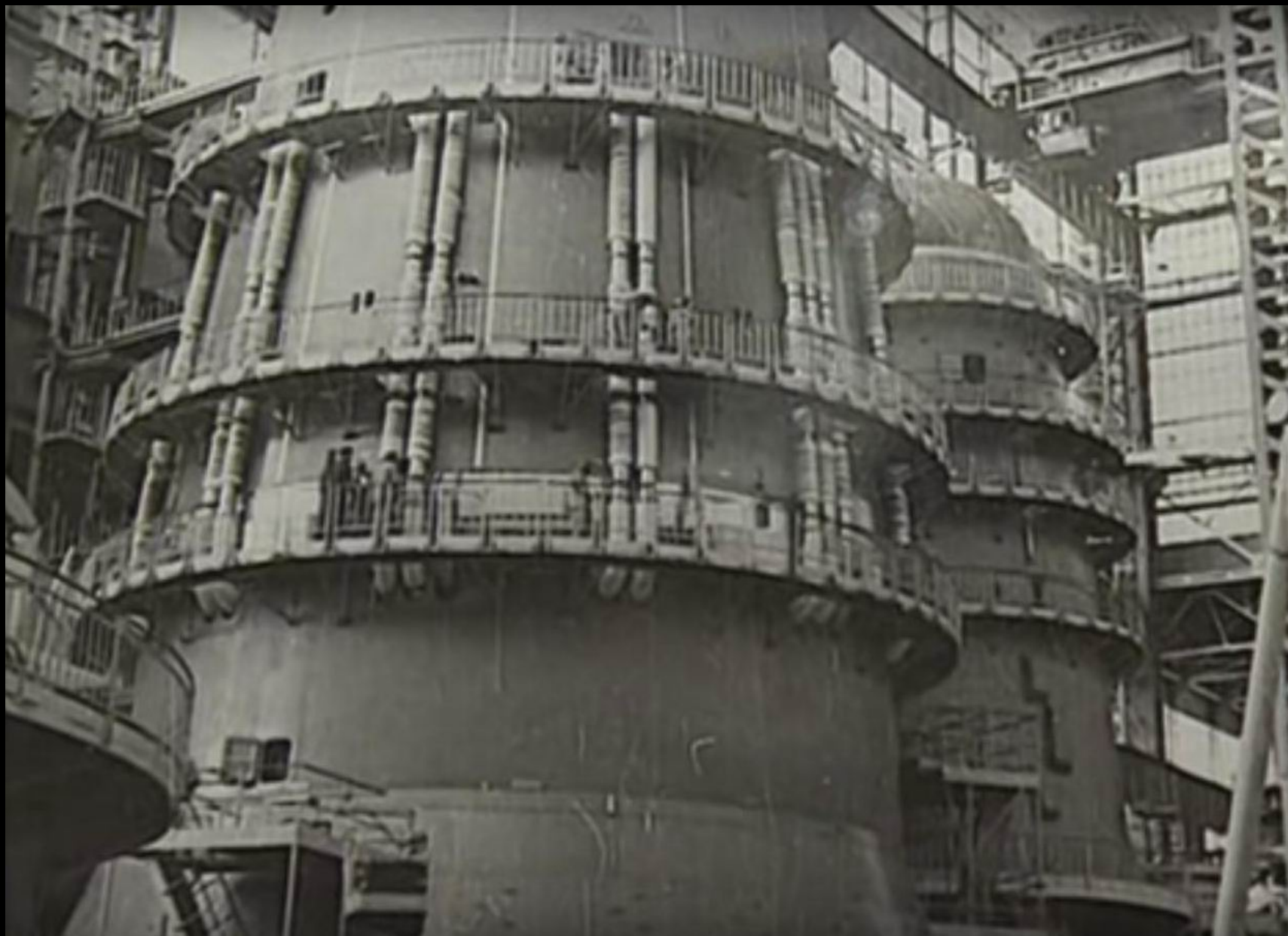

18. května 1974













1967: vývoj automatického odběru vzorků

L-1: Pilotovaný oblet Měsíce.

L-2: Automatické lunární vozidlo.

L-3: Pilotované přistání na Měsíci.

L-4: Lunární orbitální stanice.

L-5: Lunární vozidlo s posádkou.



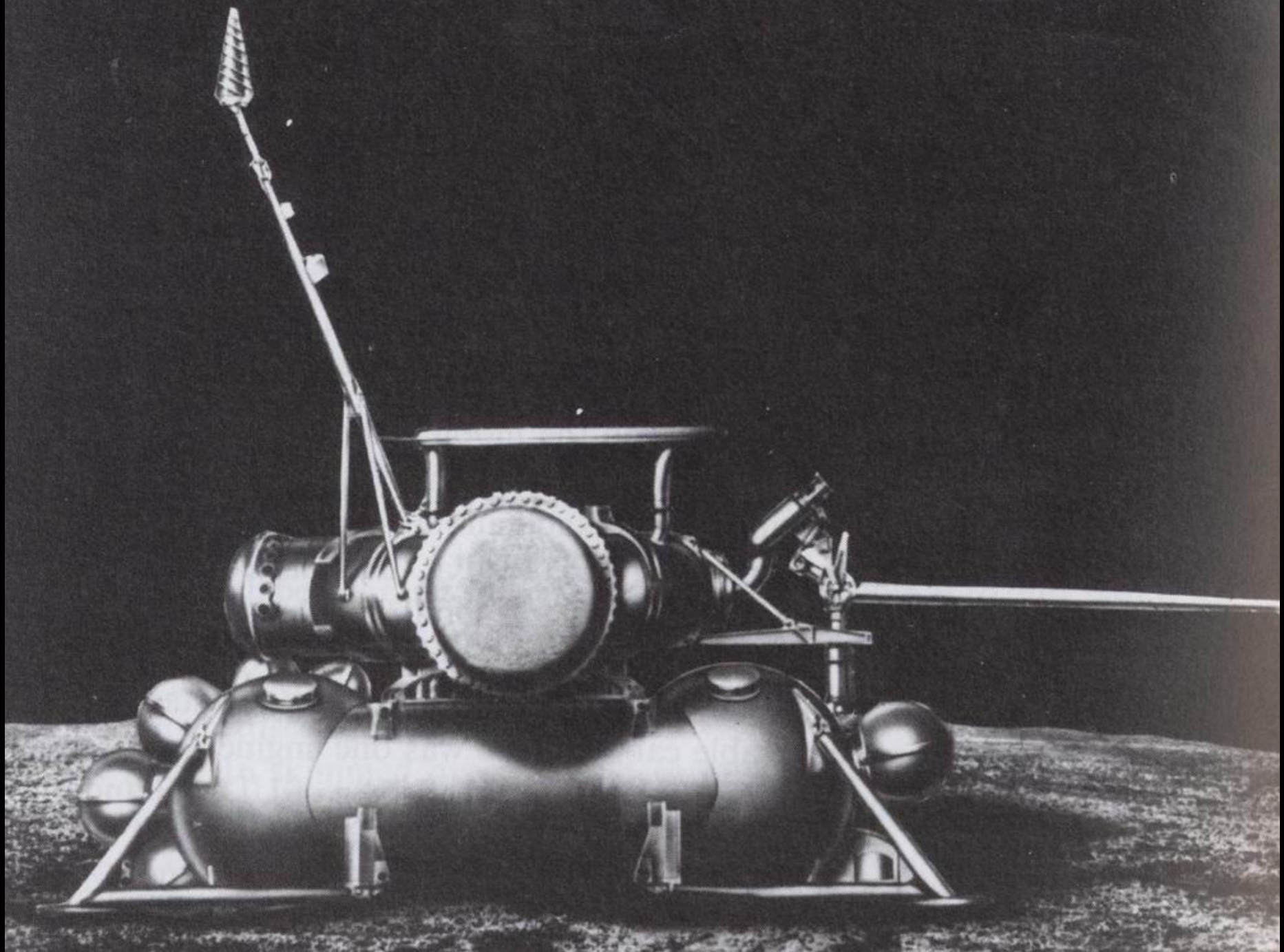

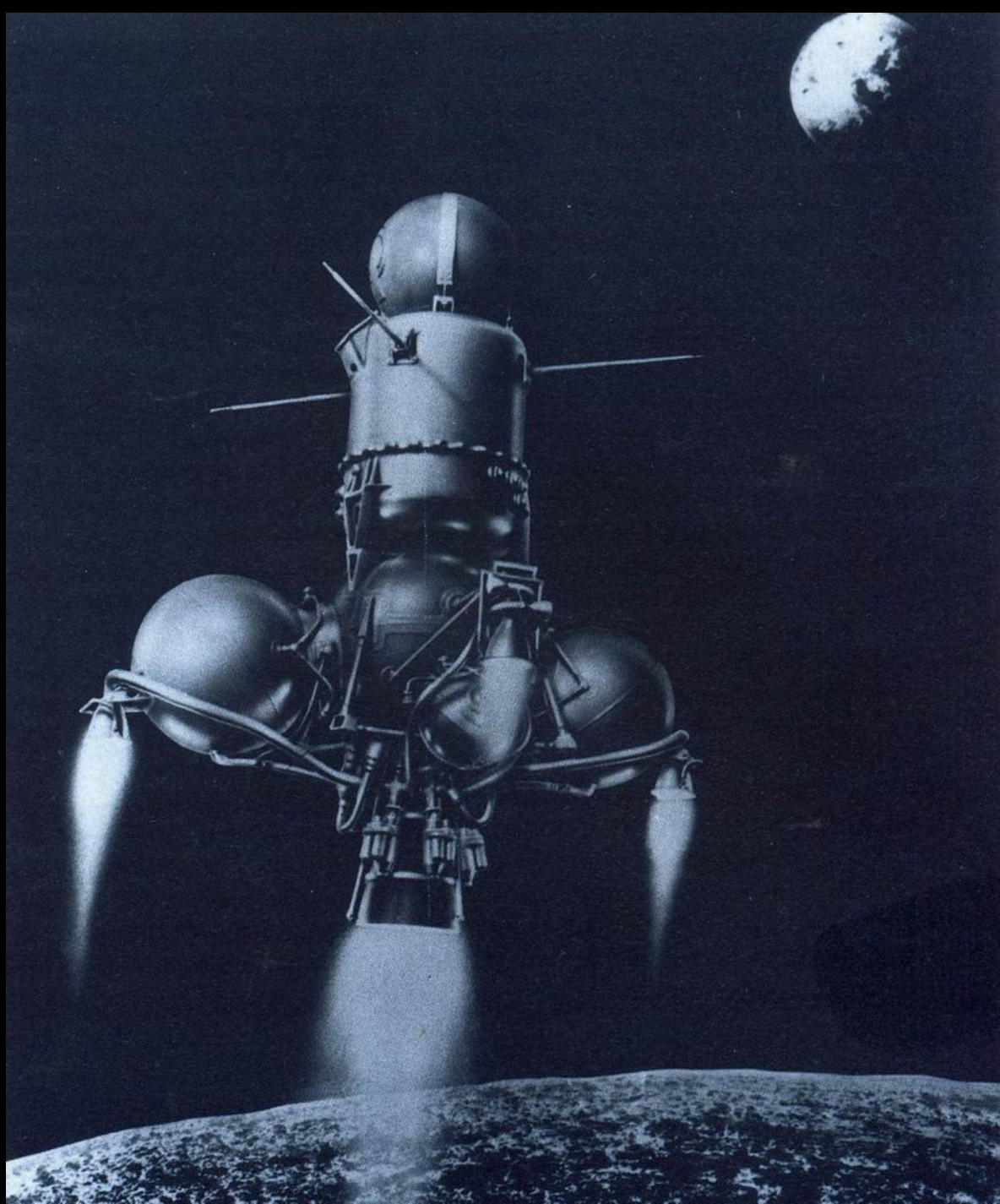

1968: stavba pěti kusů

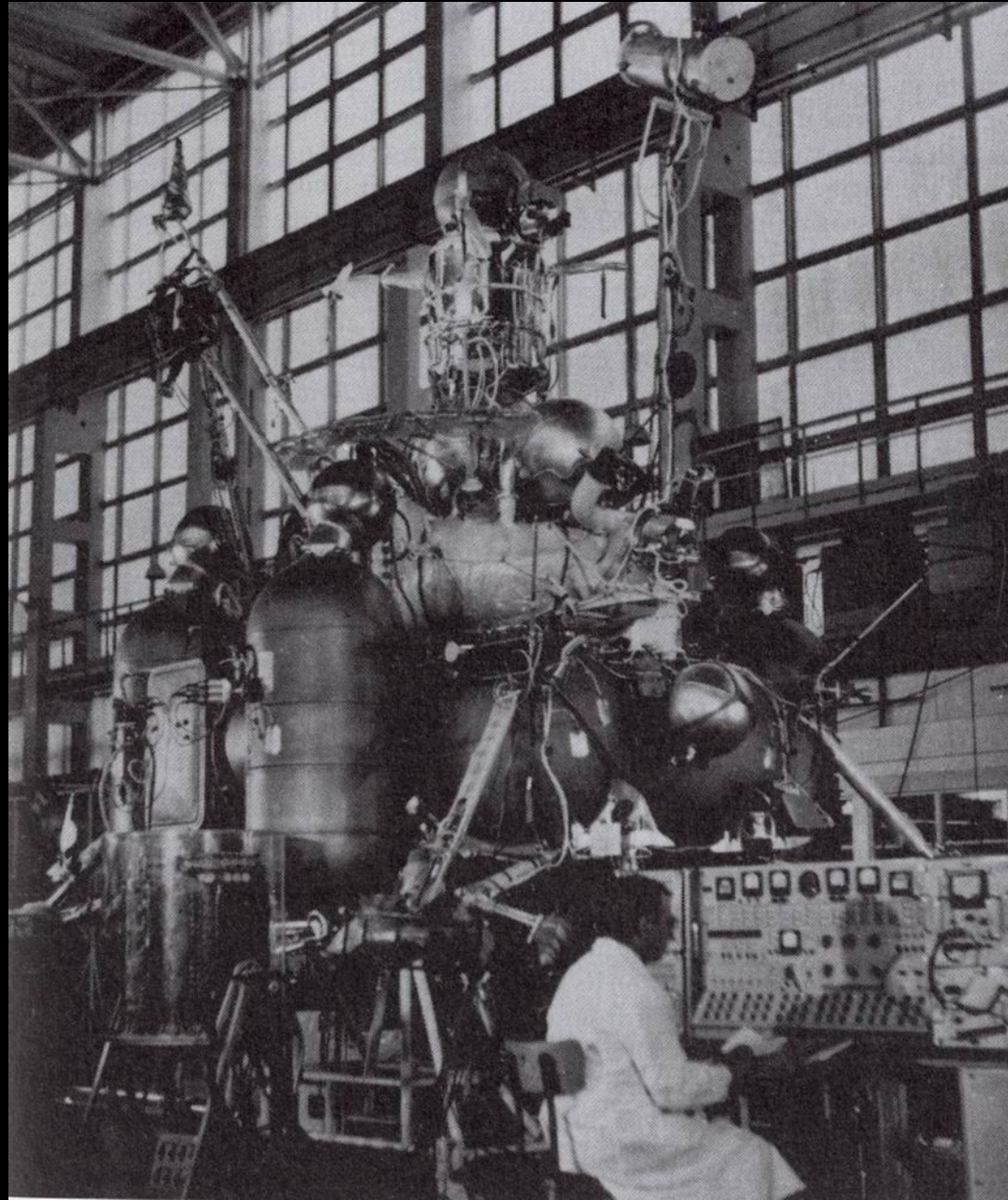

13. června 1969

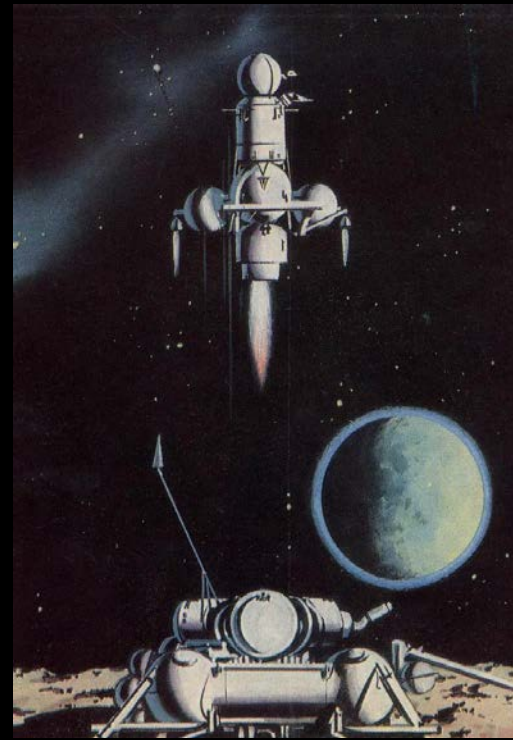

13. července 1969 – Luna-15

23. září 1969 – Kosmos-300

22. října 1969 – Kosmos-305

6. února 1970

12. září 1970: Luna-16

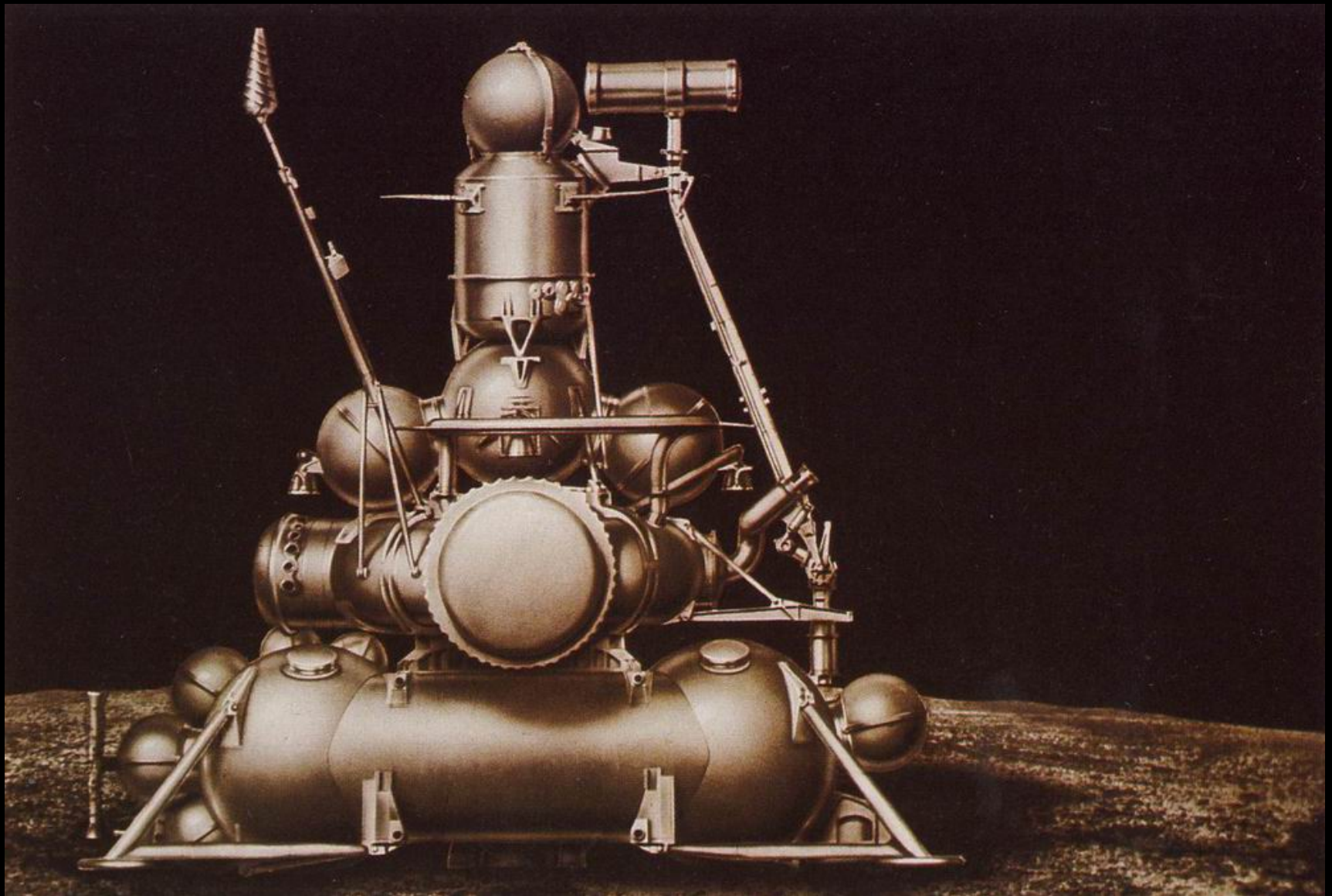

Moře plodnosti, přistání 2,5 m/s.

2. října 1974 - Luna-23

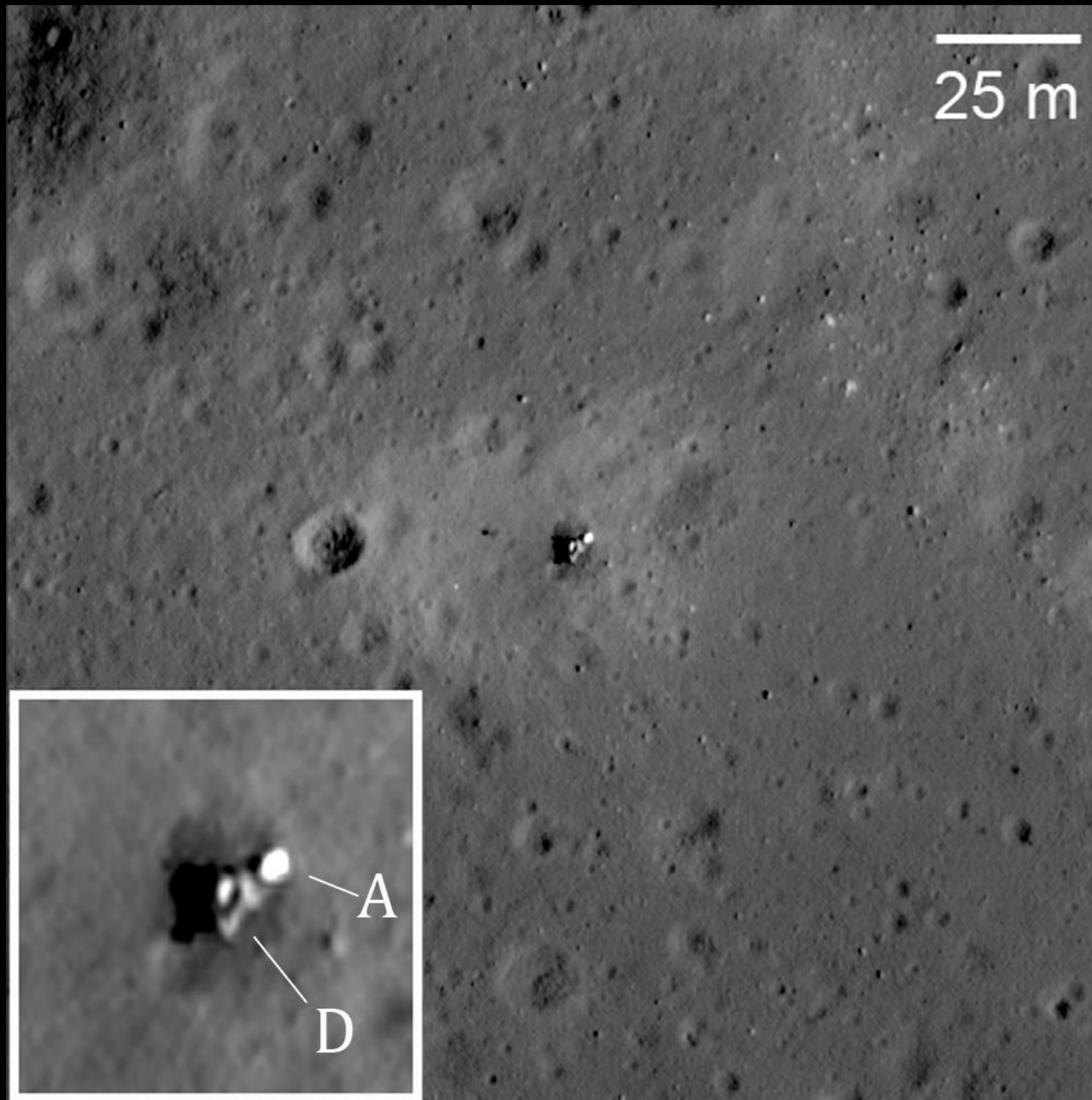

Jedenáct pokusů o odběr



2019





Orteigova cena







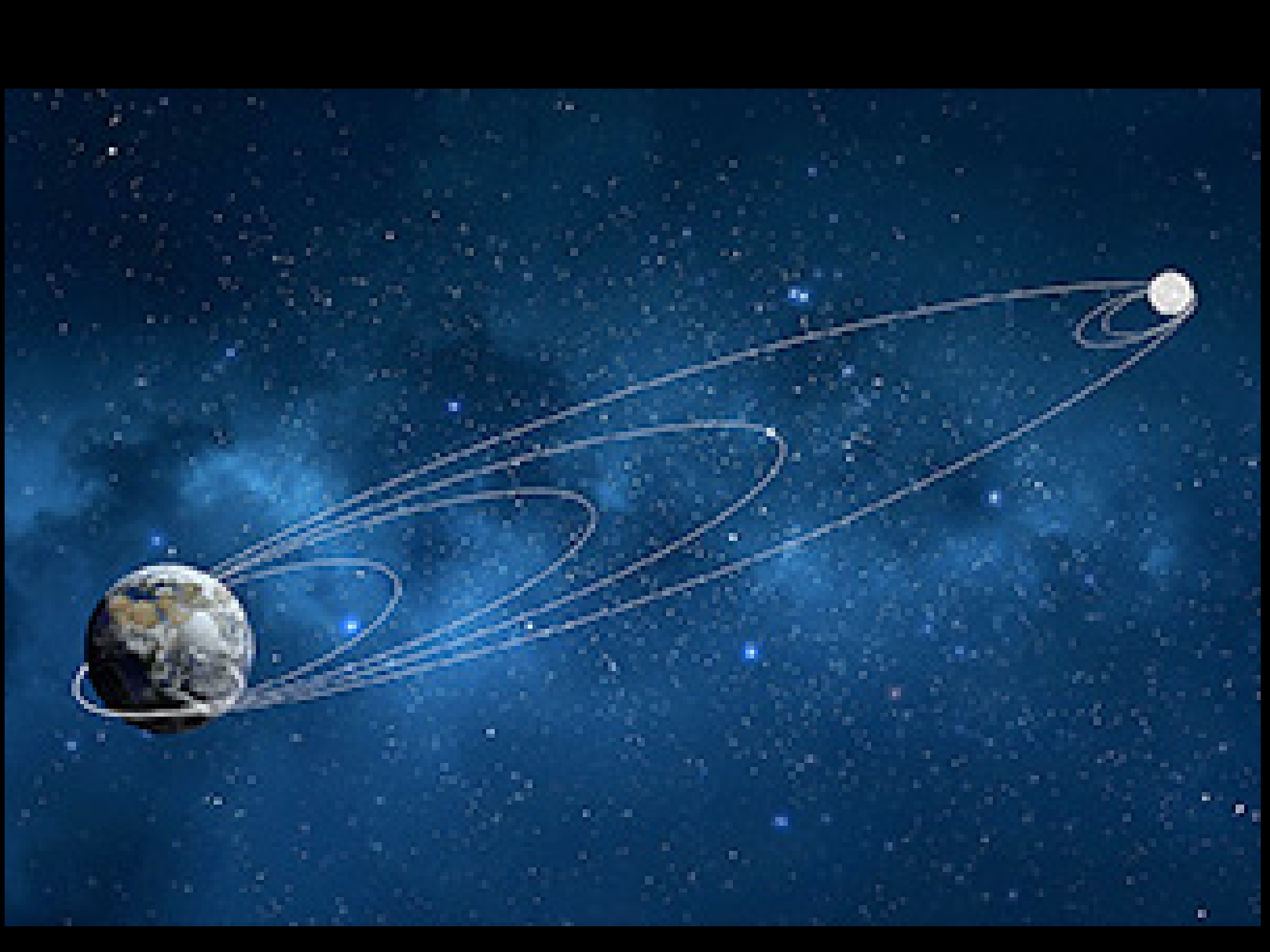

A white card with the Israeli flag and text. The card features the Israeli flag (a white field with two horizontal blue stripes and a blue Star of David in the center) at the top. Below the flag, the text reads "עם ישראל חי" (Am Yisrael Chai) in Hebrew, followed by "SMALL COUNTRY, BIG DREAMS" in English. At the bottom of the card, there are three logos: IAI, SPACEIL, and Google XPRIZE.

עם ישראל חי
SMALL COUNTRY, BIG DREAMS
IAI SPACEIL Google XPRIZE

Chandrayaan 1







Chang'e

2007 - 1

2010 - 2

2013 - 3

2018 - 4

2019? - 5



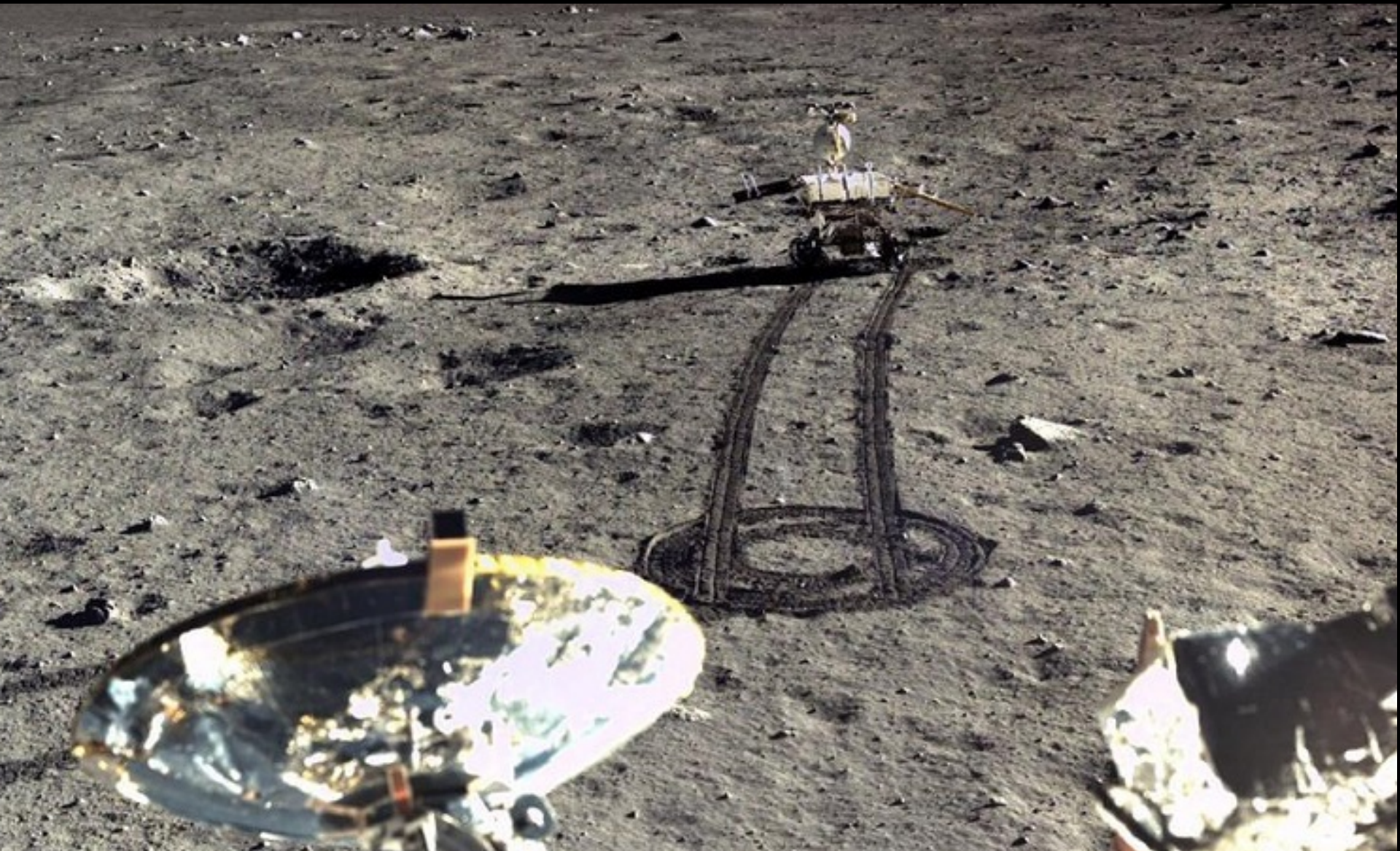

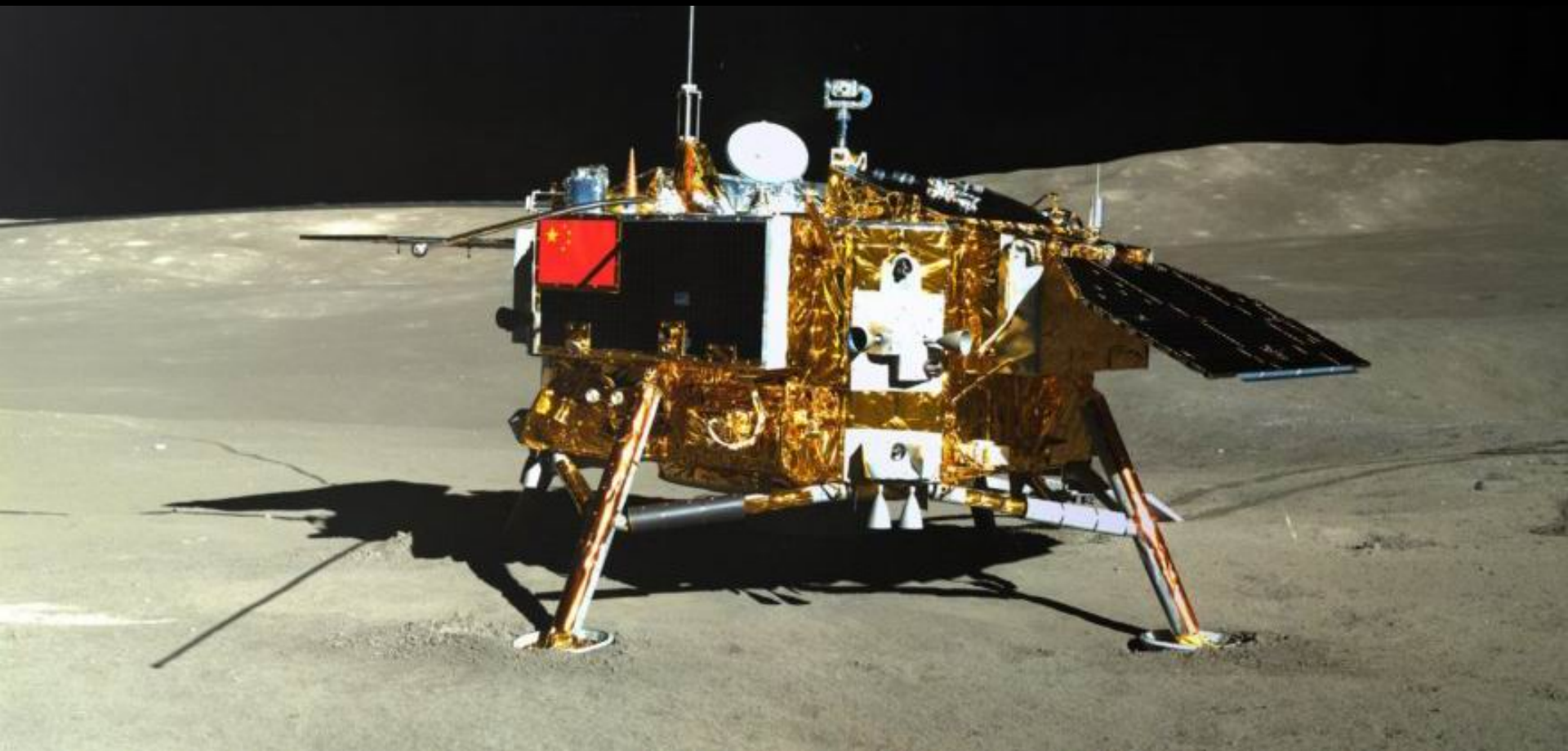

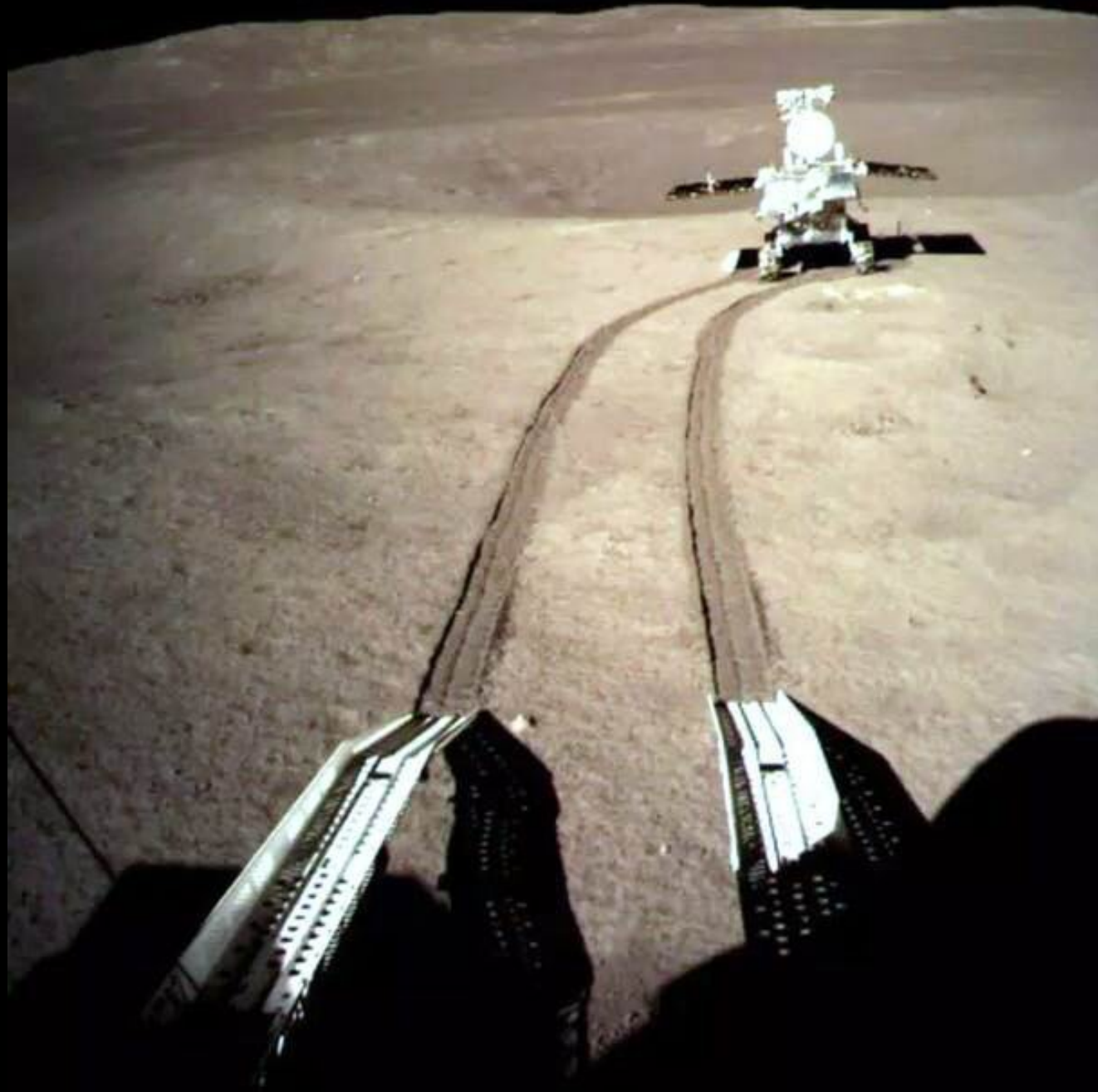

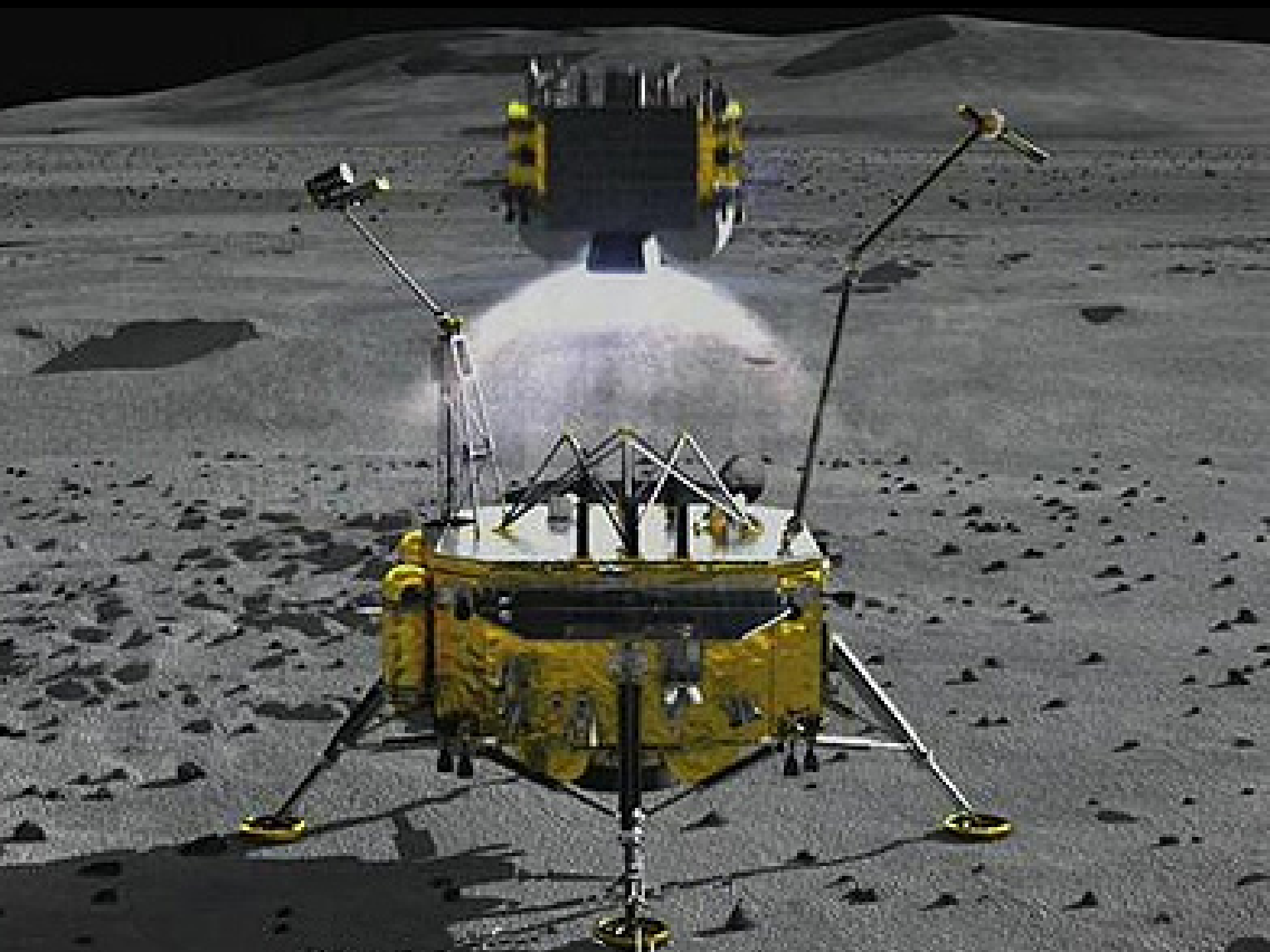





中国探月
CLEP

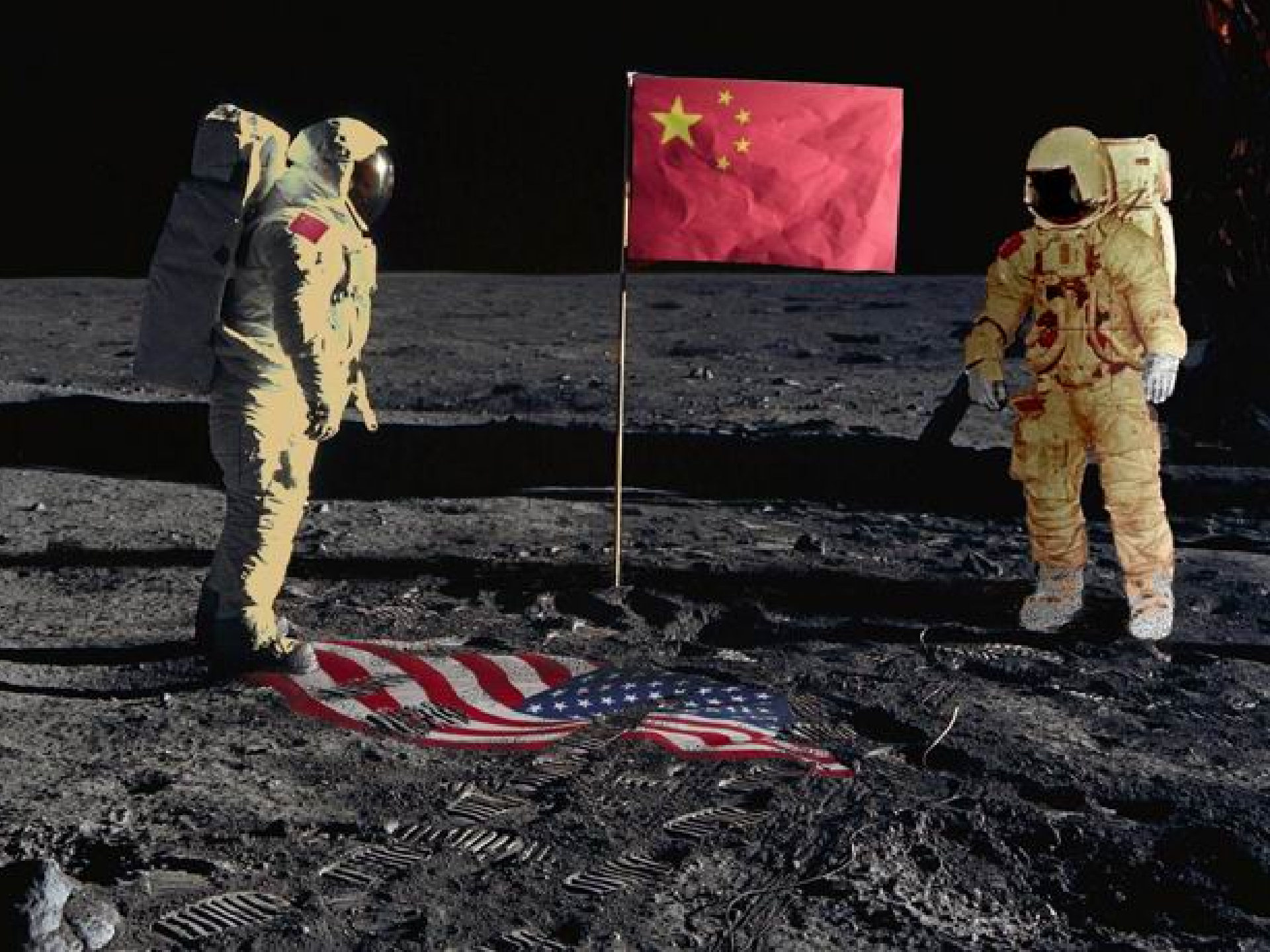

**Děkuji
za pozornost!**

Ing. Tomáš PŘIBYL

tomas.pribyl@seznam.cz

www.kosmonaut.cz

